



BREVINI[®]

Motion Systems

DC1G1A1_A10-A20R1
01 2023

Product Catalog

Helical and Bevel Helical Gearboxes **Brevini[®] Posired 2 PB/PLB Series**

Output torque up to 120.000 Nm

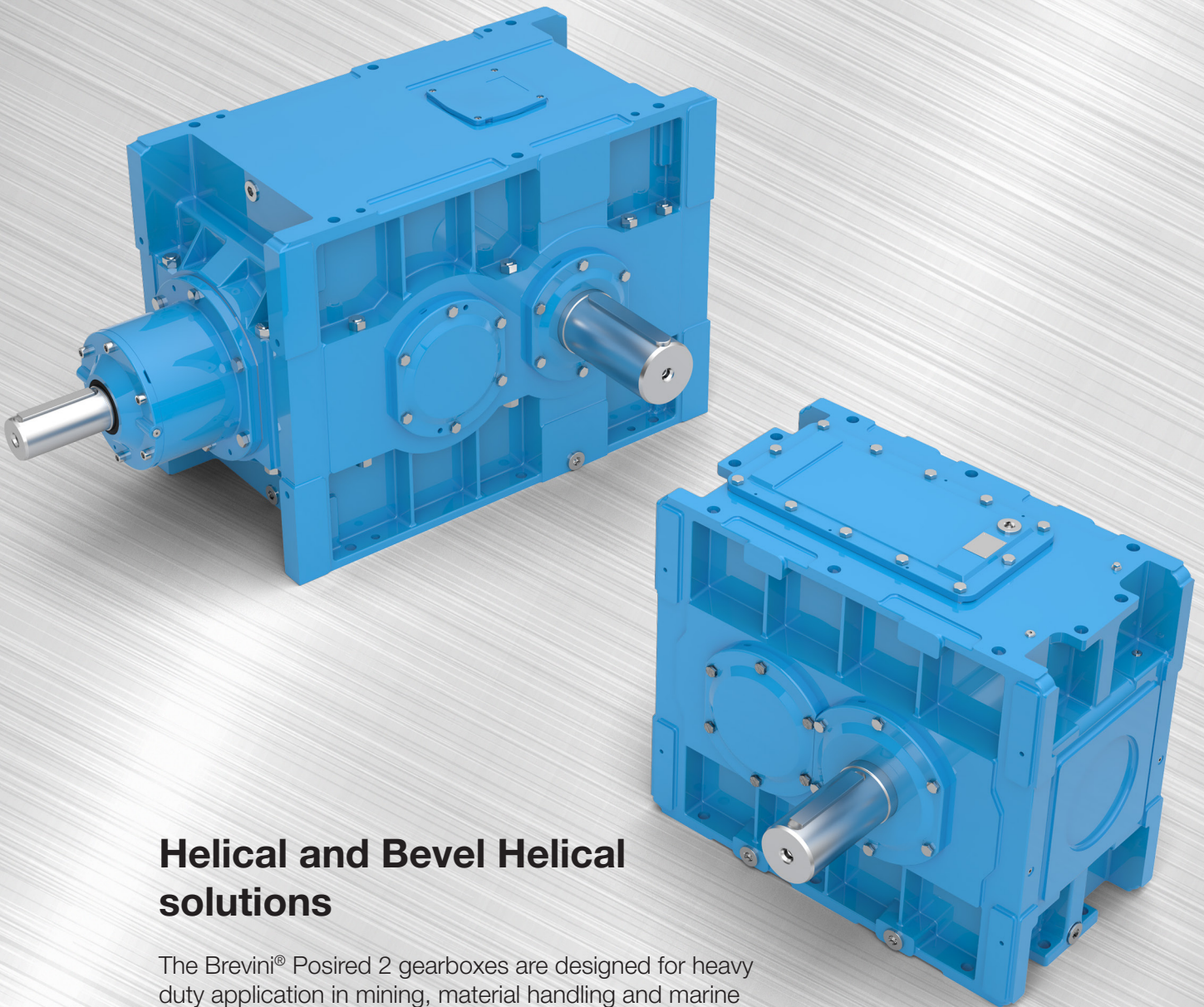

Helical and Bevel Helical solutions

The Brevini[®] Posired 2 gearboxes are designed for heavy duty application in mining, material handling and marine application. They ensure high performances in demanding applications based on their modularity and a wide range of combinations.



BREVINI[®]

Motion Systems

© 2023 Dana Limited. All rights reserved.

The product images and drawings shown are for illustration purposes only and may not be an exact representation of the product. We reserve the right to change or modify our product specifications, configurations, or dimensions at any time without notice.





Technical description	4
Symbology	7
Gear unit conception	8
Housing surfaces	9
Shaft arrangement and sense of rotation	10
Designation for order	13
Gear unit selection	14
Radial and axial loads (inquiring form)	16
Application factor	17
Technical data	21
Excat ratio	26
Mass moment of inertia	27
Dimensions	29
Optional housing bores	39
Motor bell housings	42
Hollow shaft with keyway	44
Hollow shaft with keyway and labyrinth	45
Hollow shaft with shrink disc	46
Hollow shaft with shrink disc and labyrinth	47
Flanged shafts	48
Additional shaft	49
Accessories	51
Other products	68
Conversion factors	70

Dana has introduced the introductive index and bookmars, which allow you to arrive and print the relevant section faster. Clicking the Dana logo at the bottom page, you'll come back to the index.

POSIRED 2

is Dana Motion Systems Deutschland GmbH innovative product line. These superior gear units are produced with state of the art design, material, and manufacturing technologies for maximum power and reliability within a cost-effective package.

The Dana Motion Systems Deutschland GmbH ISO 9001:2015 quality assurance system for design, development, production, assembly, and after-sales service guarantees an uniformly high World-class standard.

POSIRED 2

is an “intelligent” gear concept:

- because the design has a high degree of standardization, giving optimum availability and short delivery times
- because a cost effective selection for each application is assured by a torque-dense product range
- because it offers more advantages owing to:
 - high product quality from a robust design
 - high product flexibility allows for more versatile applications and tailor-made production from a modular construction system

Construction types:

- 1 stage helical gears
- 2 stage bevel helical gears
- 6 frame sizes available

Construction and product configurations:

- horizontal, vertical an upright designs with attachment on all 6 casing-surfaces
- spiral bevel spur gears available for compact, right angle drivess
- right angle drives available with vertical driven shafts
- with output shaft as solid, flanged, or hollow with key or shrink disk
- with motor bell housing
- with base plate for the motor and the drive unit
- with back stop
- with auxiliary drive
- with overriding clutch
- with flange for output side attachments

Output torques

T2 from 5700 Nm to 113000 Nm

Ratios

$i_N = 1.25$ to 5.6 for spur gears

$i_N = 5.6$ to 22.4 for bevel-helical gear units

Housing:

- Compact one piece casings for frame sizes 16 to 31
- Split casings for frame sizes 40 and 45
- Greater bore diameters for large roller bearings with high load carrying capacity
- The design simplifies assembly and dismantling of the gear units
- Designed utilizing the latest technologies in acoustics and Finite Element Analysis to produce superior noise reduction and housing rigidity with optimal weight savings
- Material: grey cast iron casting as standard, nodular cast iron or welded steel on request

Gears:

- Helical gears for reduced noise, case hardened and ground
- Heat treatment in PIV's dedicated hardening bay for highest quality
- Profile corrections for optimum inertia quality
- Spiral bevel gears (cyclo-paloid tooth form) hardened and lapped, HPGS or ground
- Calculation checks possible in accordance with DIN 3990, ISO 6336, AGMA and classification Company standards
- Gear toothing quality 6 acc. to DIN

Shafts:

Available types of **output shafts**:

- Solid shaft
- Double extended solid shaft
- Hollow shaft with key
- Hollow shaft with shrink disc
- Flanged shaft
- Splined hollow or solid shaft

Available types of **input shafts**:

- Solid shaft
- Double extended solid shaft for helical gear units
- Additional intermediate exterior shaft end for all gear unit types

Keys

acc. to DIN 6885/1 supplied by Dana Motion Systems Deutschland GmbH.

Center holes

on the shaft ends acc. to DIN 332 form DS

D [mm] 20 25..30 35 40..50 60..85 > 85

Thread M6 M10 M12 M16 M20 M24

Roller bearings

The lifetime calculations of the roller bearings assumes the highest expectations of all engineering parameters

Seals

Standard seal systems available for input and output shafts:

- Radial shaft seals in various materials
- Radial shaft seals with additional dust lip
- Second radial shaft seal with intermediate grease-filled chamber
- Greased labyrinth seals also with radial shaft seals
- No-contact seals
- Maintenance cover with reusable seal

Lubrication:

- Gear wheels and roller bearings are oil-bathed as standard
- Standardized injection lubrication systems with shaft or motor driven pump are available as options
- Oil dipstick as standard for horizontal gear units
- Oil sight glass as standard for vertical gear units

Cooling

Additional cooling devices available as standard are:

- Mechanical or Electrical fan cooling
- Cooling coil
- External oil-air cooler with oil/air or with oil/water heat exchanger

Torque arms

available on request with 1 or 2 ball-and-socket joint.

Motors and driving engines:

- Motors according to DIN, VDE, IEC or other standards
- Speed controlled three phase current drives with the necessary accessories,
- Combinations with mechanical continuously variable units of Dana Motion Systems Deutschland GmbH.

Motor supports

available as standard:

- Motor bell housings
- Motor brackets
- Base plates as support of the motor and the gear unit

Couplings

At the output suitable for standard output shafts and gear torques:

- Elastic couplings
- Gear coupling
- Barrel coupling
- Multiple disc coupling
- other coupling types on request

At the input, suitable for standard drive shafts and gear torques:

- Flexible couplings
- Hydrodynamic couplings
- other couplings on request

Backstops

available as standard, accessible in a closed housing.

Accessories:

















- Heating element for very cold conditions
- Operational monitoring systems for speed, torque, temperature, oil flow, oil level, and other conditions
- Diagnostic systems also available

General information:

- Dimension sheets are available as CAD files for various IT systems and interfaces.
- Computer programs for drive selection.
- Gear, shaft and bearing calculation with proof of calculation.
- The degree of protection corresponds to IP 55.
- Information on the weight of the gear unit and the amount of gear oil are guide values. Exact values can be found on the gear unit nameplate or technical description.

Scope of delivery, installation and commissioning:

- The delivery takes place without oil filling.
- Transport aids such as eye bolts are not included.
- Oil type and oil quantity according to the nameplate or technical description
- Recommended quality: CLP according to DIN 51517 or see technical description
- The standard preservation under normal transport and storage conditions is sufficient for a period of 6 months.
- Installation and commissioning according to Brevini Motion Systems operating instructions
- On request, we can supply the legally prescribed contact protection on rotating parts.
- Available, for gearboxes with hollow shaft, protection cover for shrink disk.

Dimensions	
Symbol referring to gear unit type PB	
Symbol referring to gear unit type PLB	
Symbols identifying the gear unit stages (1, 2)	 
Symbols describing kind of output shaft: V = Solid shaft H = Hollow shaft with key G = Hollow shaft with shrink disc F = Flanged shaft	 V  G  H  F
Gear unit weight [kg]	
Lubrication	
Oil quantity in liters [l]	
Type of oil plug on gear units	
Filling plug	
Oil level	
Oil drain	
Breather	
Reference to page	

MONOBLOCK HOUSING

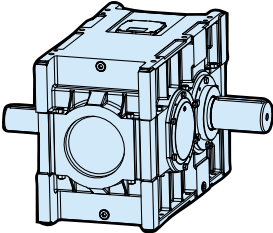
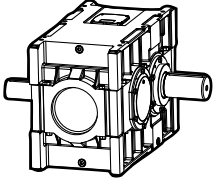
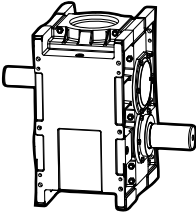
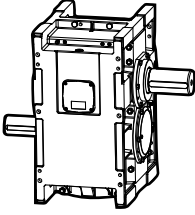
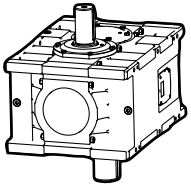
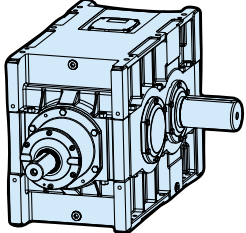
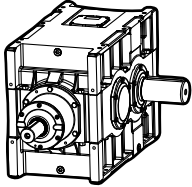
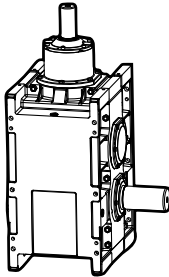
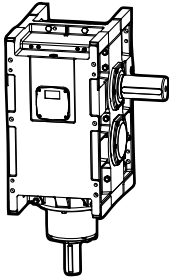
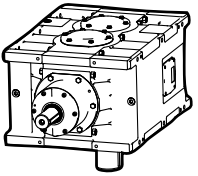
MONOBLOCK HOUSING				
Construction types	Mounting positions			
	R	S	T	U (on request)
	Horizontal, output shaft horizontal	Vertical, output shaft below	Vertical, output shaft above	Horizontal, output shaft vertical
PB	Helical gear units			
				
		on request	on request	
PLB	Bevel-helical gear units			
				

MONOBLOCK HOUSING

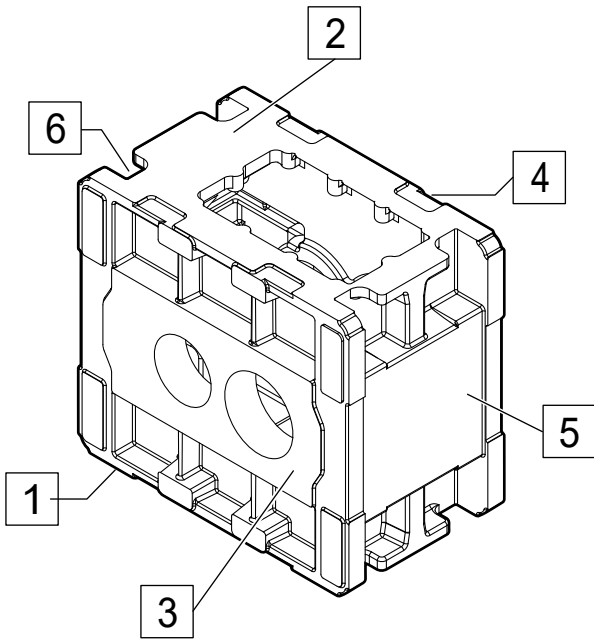

Designation of carter surfaces (1 ... 6).
Permissible mounting positions: see dimension sheets.

Example:

R1 = R for horizontal mounting position; 1 for surface 1 below

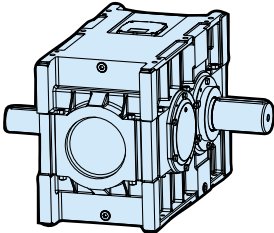
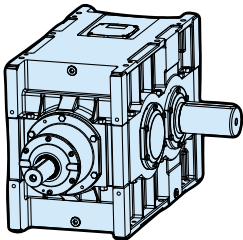
Type	MONOBLOCK HOUSING	Mounting positions and surfaces		
Helical gears		PB	R1	10
Bevel-helical gears		PLB	R1, S5, T6	11

PB

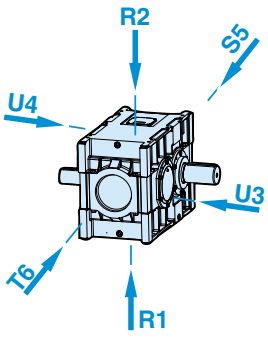

R1: Mounting positions and surface below

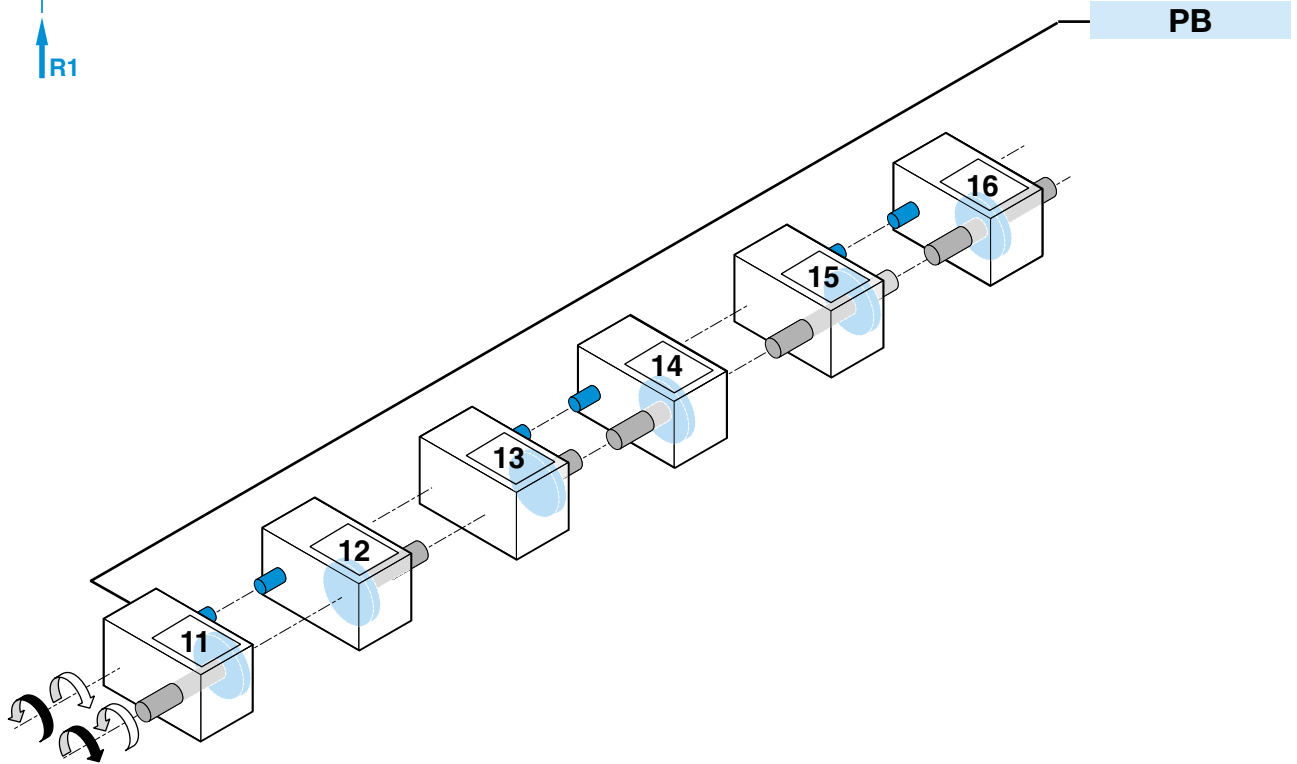

Input shafts
Output shafts

PLB

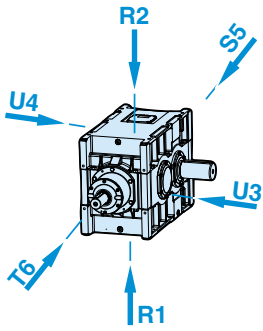

R1: Mounting positions and surface below

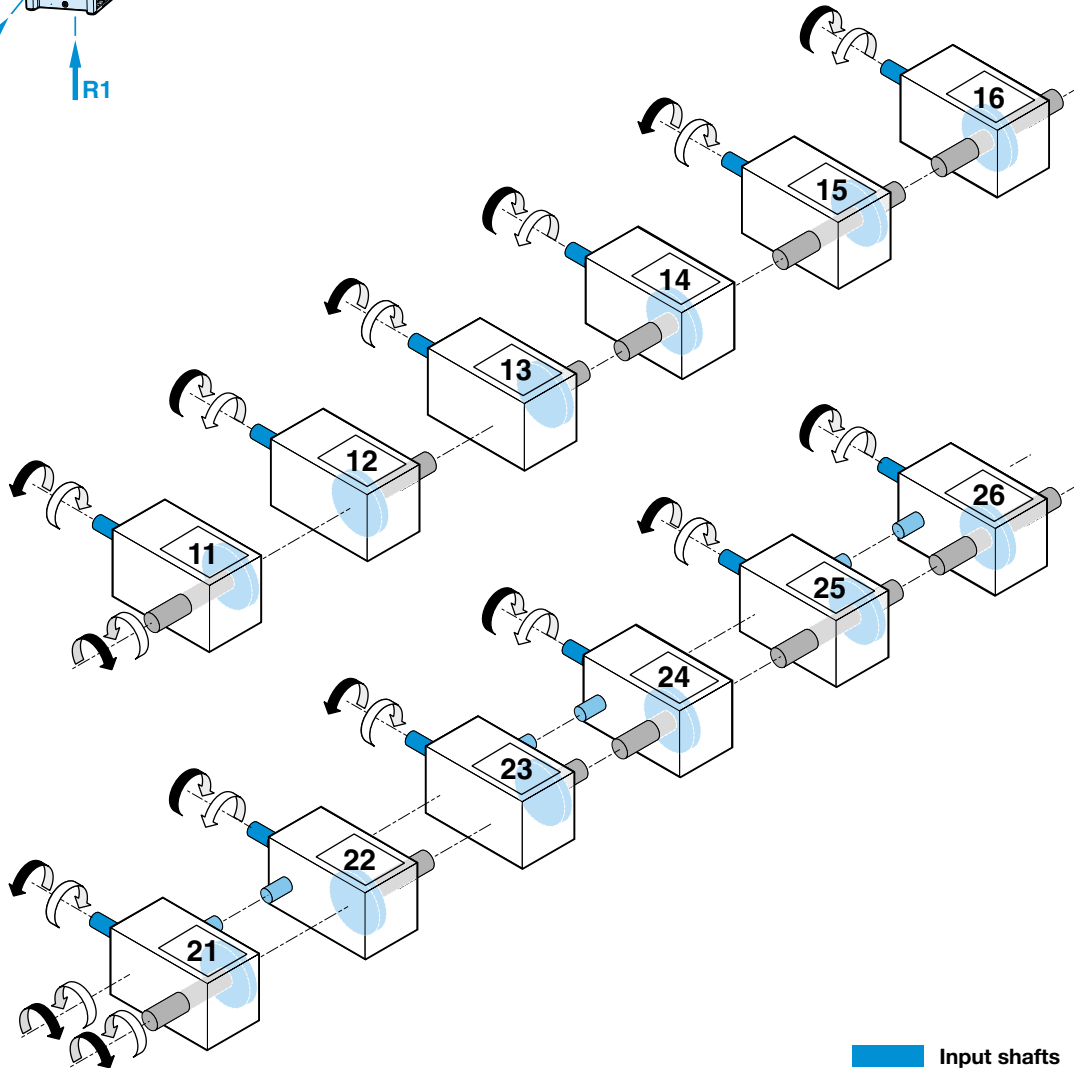

PLB

- Input shafts
- Output shafts
- Double extended input shafts

PLB

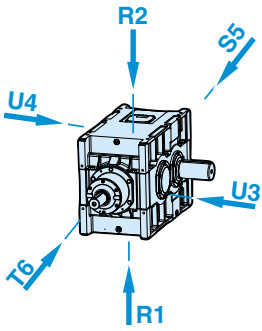

R1: Mounting positions and surface below

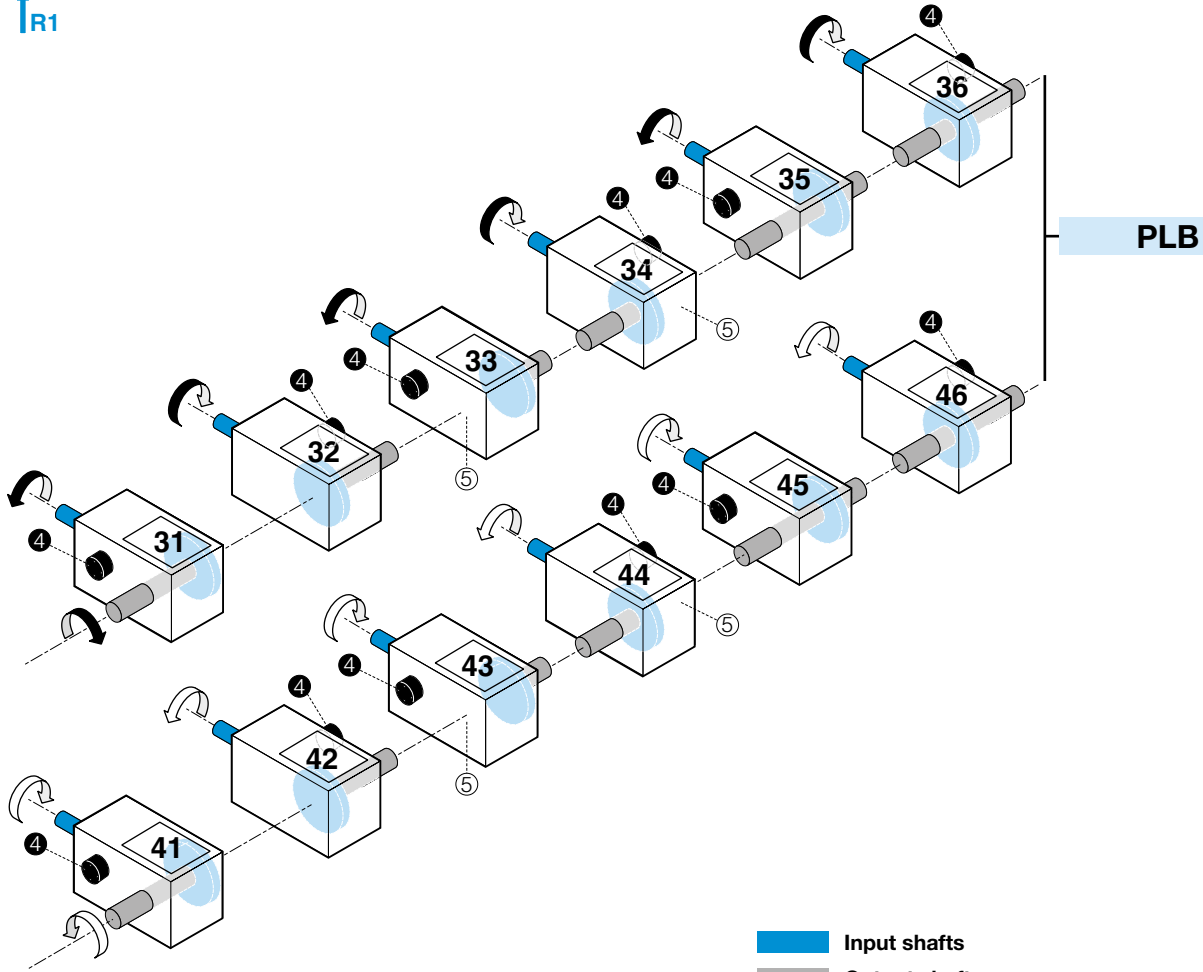

■ Input shafts
■ Output shafts
4 Hollow shaft with backstop from size ≥ 31

52

5 Hollow shaft with shrink disc only from size ≥ 31

46

K	-	PB	20	-	R	1	1	-	V	11	-	5	-	Z	1
---	---	----	----	---	---	---	---	---	---	----	---	---	---	---	---

Motor attachment

K	K	Motor bell housing
	M	Motor base plate
	J1	Swing base
	J2	Motor scope

Type

PB	PB	Helical gear units
	PLB	Bevel-helical gear units
		Compact drives

Size

20	16...45
-----------	----------------

Mounting position

R	R	Horizontal, output shaft horizontal
	S	Vertical, output shaft below
	T	Vertical, output shaft above
	U	Horizontal, output shaft vertical

Carter surface below

1	1...6
----------	--------------

Mounting arrangement

1	0	Shaft mounted with torque reaction arm
	1	Surface 1
	2	Surface 2
	3	Surface 3
	4	Surface 4
	5	Surface 5
	6	Surface 6
	7	Output flange

Output shaft

V	V	Solid shaft with keyway
	H	Hollow shaft with keyway
	G	Hollow shaft with shrink disc
	F	Flanged shaft

Shaft positions, directions of rotation, position of back stops

11	
-----------	--

Nominal ratio

5	
----------	--

Addition

Z1	1	Fan cooling
	2	2 fans
	3	Cooling coil
	4	Fan cooling + cooling coil
	8	2 cooling coils
	9	2 cooling coils + 1 fan

- Establish the type of gear unit and mounting arrangement

- Ratio $i_{\text{sol}} = \frac{n_1}{n_2}$

- Selection of the appropriate nominal ratio i_N (or the actual ratio i_w Page 58...62)

- Determine the gear unit size
Check the gear unit power

$$P_N \geq P_e \cdot f_K$$

f_K = Gear unit application factor, see table 1 (page 31)

Checking the peak torque

$$T_{\text{max}} \leq 9550 \frac{P_N}{n_1} \cdot f_E \cdot f_R$$

f_E = Operating frequency factor, see table 2 (Page 31)

f_R = Reversal factor, table 3 (page 31)

- Checking the thermal capacity

$$P_t \geq P_e$$

$$P_t = P_t \cdot f_w \cdot f_A$$

n_1	[min ⁻¹]	input speed	T_{max}	[Nm]	Start-up or maximum motor or braking torque
n_2	[min ⁻¹]	output speed	P_t	[kW]	Thermal capacity
i_{sol}		Desired ratio	P_{t0}	[kW]	Thermal capacity for drive without additional cooling
i_N		Nominal ratio	P_{t1}	[kW]	Thermal capacity with air cooling
i_w		Actual ratio	P_{t3}	[kW]	Thermal capacity with cooling coil
P_M	[kW]	Motor power	P_{t4}	[kW]	Thermal capacity with air cooling and cooling coil
P_N	[kW]	Nominal power output	f_w		Thermal factor
P_e	[kW]	Effective power of machine to be driven	f_A		Load factor
f_a		Gear unit application factor	ϑ_U	[°C]	Ambient temperature
f_E		Operating frequency factor	ED	[%]	Duty cycle per hour
f_R		Reversal factor			

The shaft ends are provided with shearing-loadfree couplings for torque transmission. Ask for explanations for external forces.

Design Example

Machine to be driven: Apron conveyor for crusher loading

Required output power: $P_e = 394$ kW

Speed: $n_2 = 118$ min⁻¹

Duty cycle: $ED = 100$ %

Starts per hour: 10

Ambient temperature: 24 h/day

Ambient temperature: $\vartheta_U = 40$ °C

Installation in the open air, constant strong blast given.

Driving Machine:

Three-phase motor

Motor output: $P_M = 500$ kW

Motor speed: $n_1 = 1480$ min⁻¹

Max. motor torque: $T_{\text{max}} = 3650$ Nm
(pull-out torque)

Selection

1. A bevel helical gear unit for horizontal installation in a solid shaft is required.

2. Ratio:

$$i_{\text{sol}} = n_1 / n_2 = 1480 / 118 = 12.54$$

Nominal ratio: $i_N = 12.5$

The power data page 22 comes up with type **PLB**.

3. Determine the gear unit size

Check the gear unit power

$$P_N \geq P_e \cdot f_K$$

With application factor f_K from table 1 (page 15-18):

$f_K = 1.5$ (upper value for continuous use)

$$P_{N\text{ erf}} \geq 394 \text{ kW} \cdot 1.5 = 741 \text{ kW}$$

Selected: Gear unit **PLB 40** with $P_N = 789 \text{ kW}$

4. Checking the peak torque:

$$T_{\text{max}} \leq 9550 \cdot \frac{P_N}{n_1} \cdot f_E \cdot f_R$$

With operating frequency factor f_E from table 2 (page 18): $f_E = 1.6$

With reversal factor f_R from table 3 (page 18): $f_R = 1.0$

$$T_{\text{max}} \leq 9550 \cdot \frac{394 \text{ kW}}{1480 \text{ min}^{-1}} \cdot 1.6 \cdot 1.0 = 4068 \text{ Nm}$$

$3650 \text{ Nm} < 4068 \text{ Nm}$ O.K.

5. Checking the thermal capacity:

$$P_t \geq P_e \quad \text{with} \quad P_t = P_{t_} \cdot f_W \cdot f_A$$

$P_{t_}$: P_{t0} Thermal capacity without additional cooling

P_{t1} Thermal capacity with ventilator

P_{t3} Thermal capacity with cooling coil

P_{t4} Thermal capacity with ventilator and cooling coil

With thermal factor f_W from table 4 (page 23): $f_W = 0.71$ for $\vartheta_U = 40 \text{ }^\circ\text{C}$ and $ED = 100\%$

With a duty cycle factor f_A from table 5 (page 23): $f_A = 0.9$ for $\frac{P_e}{P_N} = \frac{394}{789} \cdot 100\% = 49\%$

Gear units without additional cooling: $P_{t3} = 959 \cdot 0.9 \cdot 0.71 = 613 \text{ kW}$

With $P_{t0} = 83 \text{ kW}$ from page 23

$$P_e = 394 \text{ kW} < P_t = 613 \text{ kW}$$

A cooling coil is necessary.

Order code:

PLB	40	-	R1	1	-	V	12	-	12.5	Z3
-----	----	---	----	---	---	---	----	---	------	----

RADIAL AND AXIAL LOADS (INQUIRING FORM)

To be sent to the Dana area contact person

Mr. / Mrs. _____
 Company _____
 Street _____
 Postal code / Locality _____
 Country _____
 Telephone _____
 Telefax _____
 E-Mail _____

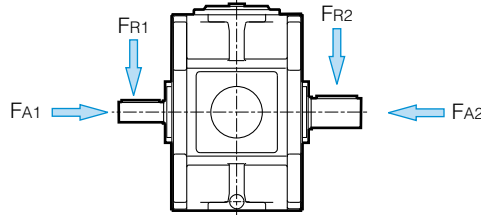
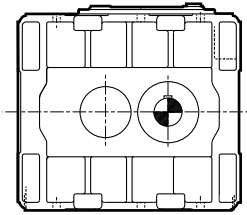

To the verification of the admissible strain of the input shaft and the output shaft due to exterior forces.

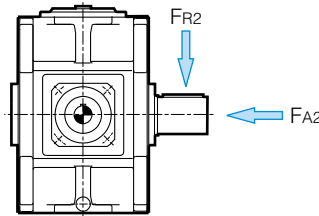
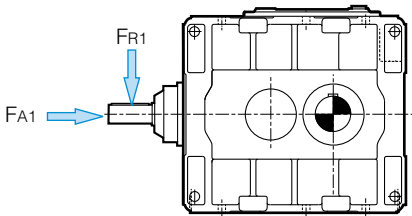

Specify please with negative sign the forces working in a direction opposite to the one represented.

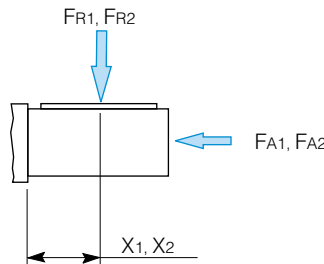
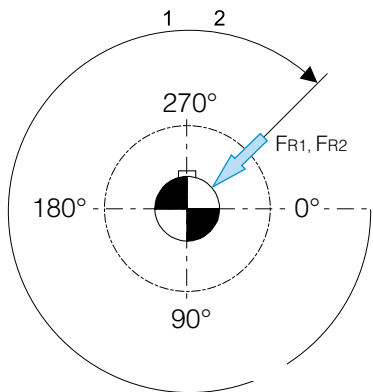

F_{R1} [N] = _____ **Radial loads**
 F_{A1} [N] = _____ **Axial loads**
 X_1 [mm] = _____ **Distance of load application**
 α_1 = _____ **Direction of load**

F_{R2} [N] = _____ **Radial loads**
 F_{A2} [N] = _____ **Axial loads**
 X_2 [mm] = _____ **Distance of load application**
 α_2 = _____ **Direction of load**



Gear unit application factors are in line with DIN standard no. 3990 part 11 (edition 2/89) and are based on our experience for normal operating conditions. Changes in the necessary drive selection may take place after stating the exact operating conditions.

Table 1: Gear unit application factor f_a 1)	Intermitt. Use (0,5 h)	Shifts 2)
Blowers, Ventilators		
Air cooler		1.4...1.5
Axial blowers	0.8	1.0...1.25
Cooling tower fans	1.2	1.6...1.7
Heat exchangers		1.5
Rotary piston blowers	1	1.25...1.5
Suction draught blower	1	1.25...1.5
Turbo exhauster	0.8	1.0...1.25
Cableways		
Continuous ropeways		1.4...1.6
Freight ways		1.3...1.4
Shuttle cableways		1.4...1.8
T-bar lifts		1.3...1.4
Cement Industry		
Concrete mixers		1.5
Crushers		1.2...1.4
Roller mills		2
Rotary kilns		2
Separators		1.6
Tube mills		1.8
Chemical industry		
Agitators for materials		
with constant density	1	1.3...1.5
with variable density	1.2	1.4...1.6
Agitators with variable gas absorbt.	1.4	1.6...1.8
Centrifuges	1	1.25...1.35
Drying kilns		1.5
Kneading machines		2
Toasters	1	1.3...1.5
Compressors		
Piston compressors		1.8...1.9
Rotary compressors		1.4...1.5
Turbo compressors	1	1.25...1.5
Conveyors		
Apron conveyors		1.2...1.5
Band elevators	1	1.25...1.5
Belt conveyors	1.0...1.1	1.2...1.4
Bucket conveyors		1.2...1.5
Canvas belt elevators	1	1.25...1.5
Cellular bucket belt conveyors	1	1.25...1.5
Chain bucket elevators	1	1.25...1.5
Circular conveyors	1	1.25...1.5
Escalators	1	1.2...1.4
Goods lifts		1.2...1.5
Hoisting engines		1.5...1.8
Passenger lifts		1.5...1.8
Rail travelling devices		1.5
Scraper chain conveyors	1	1.25...1.5
Screw conveyors	1	1.25...1.5
Sinking mine machines	1.5	1.75...2.0
Steel belt conveyors	1	1.25...1.5
Winders	1.4	1.6

Table 1: Gear unit application factor f_K ¹⁾	Intermitt. Use (0,5 h)	Shifts ²⁾
Cranes Classified acc. to FEM 1001		
Crushers		
Ball crushers		1.75...2.0
Hammer mills		1.75...2.0
Rebound crushers		1.75...2.0
Rod mills		1.75...2.0
Roller mills		2
Swinging crushers		1.75...2.0
Tube mills		1.8
Dredgers		
Bucket chain drives		1.75...1.85
Bucket wheels		1.75...2.2
Cutter heads		2.2
Dumping devices		1.3...1.5
Manoeuvring winches	1	1.25...1.5
Slewing gears		1.4...1.8
Sucking pumps	1	1.25...1.5
Travelling gears (caterpillar)	1.2	1.6...1.8
Travelling gears (rails)	1	1.25...1.5
Food Industry Machinery		
Beet sugar production		
Beet washing machines & cutters		1.5
Slicing machines	1.2	1.2
Juice boilers and refrigerators		1.4
Bottling&container filling machines	0.8	1.25...1.5
Flour bucket elevators	0.8	1.0...1.25
Kneading machines	1	1.25...1.5
Mash tubs	1	1.25...1.5
Packaging machines	0.8	1.0...1.25
Sugar cane crushers		1.25...1.5
Sugar cane knives ³⁾		1.7
Sugar cane mills ³⁾		1.7
Generators, Converters ³⁾		
Frequency converters		1.8...2.0
Generators	0.8	1.0...1.25
Welding generators	1.5	1.75...2.0
Metal Working Machines		
Crank presses		1.75...2.0
Forging presses		1.75...2.0
Hammers		1.75...2.0
Plate bending machines		1.25...1.5
Plate straitening presses		1.75...2.0
Roller levellers		1.6
Stamping presses		1.75...2.0
Metallurgical Industry		
Blast furnace blowers		1.25...1.5
Converters		1.75...2.0
Inclined furnace hoists		1.75...2.0
Mining, Stone an Clay Working Machines		
Conical crushers		2
Endless chain transporters		1.5
Jaw breakers		2
Jolters		1.5
Mine ventilating fans		1.5
Rolling crushers		1.5
Rotary crushers		2
Rotary kilns		2
Separators		1.5
Toothed roll crusher		2
Tub-pushing devices		1.5

Table 1: Gear unit application factor f_K 1)	Intermitt. Use (0,5 h)	Shifts 2)
Oil Industry		
Charging filter pumps		1.25...1.5
Flush boring pumps		1.25...1.5
Pipeline pumps		1.25...1.5
Rotary drilling equipment	1.5	1.75...2.0
Paper Machines for all types		1.8...2.5
Presses 3)		1.0...1.1
Pumps		
Centrifugal pumps	1	1.2...1.3
Charge pumps	1.5	1.75...2.0
Piston pumps	1.2...1.3	1.4...1.8
Plunger pumps		2
Sludgers	1	1.25...1.5
Rolling Mills		
Belt winders	1	1.25...1.5
Billet shears		2
Blooming- and slabbing mills		2
Capstan wheels		1.5
Chain transfer		1.5
Cold band rolling mills 3)		1.75...1.85
Cooling bed transfer frames		1.5
Continuous casting drivers 3)		1.4
Continuous shears 3)		1.5
Crank type shears	1	1
Cropping shears		2
De-scaling breakers		2
Drawing bench drives		2
High speed roller tables		1.5
Ingot conveyors		2
Ingot pushers		1.2
Looper		1.5
Loop lifter		1.5
Low speed roller tables		1.5
Plate rolling trains		2
Plate shears		2
Plate tilters	1	1.0...1.2
Plate trimming shears		1.5
Reversing blooming mills		2.5
Reversing plate mills		1.8
Reversing sheet mills		2
Reversing slabbing mills		2.5
Reversing wire mills		1.8
Rod reel & belt winders		1.5
Roll adjustment devices		1.5
Roll weighting drives	0.9	1
Roller straighteners		1.6
Roller tables continuous		1.5
Roller tables intermittent		2
Sintering belt drives		1.5
Straightening & transp. equipment		1.5
Thin sheet rolling trains		2
Transfer skids		1.5
Tube reverse equipment		1.8
Turntables (Continuous casting)		1.5
Walking beam conveyors		2
Winders		1.6
Working roller tables		2

Table 1: Gear unit application factor f_K 1)	Intermitt. Use (0,5 h)	Shifts 2)
Rubber and Plastic Industry Machinery		
Calenders		1.5
Extruders		1.5
Kneading machines		1.8
Mixers	1.0...1.4	1.3...1.7
Rolling mills		2
Rotary cooler		1.3...1.4
Textile Machines		
Calender	1	1.25...1.5
Looms	1	1.25...1.5
Printing and dyeing machines	1	1.25...1.5
Take-up rollers	1	1.25...1.5
Willows	1	1.25...1.5
Water Treatment		
Circular and longitudinal rakes	1	1.3...1.5
Filter presses	1	1.3...1.5
Flocculation agitators	0.8	1.0...1.3
Pre-thickeners		1.1...1.3
Raking equipment	1	1.2...1.3
Rotary aerators		1.5...1.7
Screw pumps		1.3...1.4
Thickeners		1.2
Water wheels		2
Wood Working Machines		
Barkers	1.5	1.75...2.0
Planing machines	1	1.25...1.5
Saw frames	1.5	1.75...2.0

Table 2: Operating frequency factor f_E					
2	1.6	1.4	1.2	1.1	1
with ... load peaks per hour					
1	2-10	11-20	21-50	51-100	>100

Table 3: Reversal factor f_R	
1.0	0.7
Steady direction of load	Reversing operations

1) Application factors apply to the following driving motors: electric motors, turbines and fluid power motors. When combustion engines are the driving force, enquiries have to be made.

2) The lower table value is for single shift operation and for lighter applications, the upper table value is for continuous use and heavier applications.

3) Design is in accordance with maximum torque.

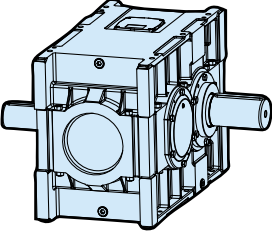
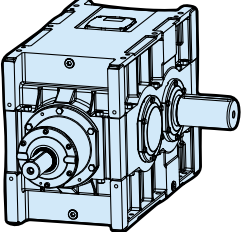
Type		Size	i_N	T_{N2} [kNm]	Efficiency η	
 Helical gear units	PB	16	1.25 - 5.6	7	0.98	20
		20	1.25 - 5.6	13		
		25	1.25 - 5.6	22		
		31	1.25 - 5.6	38		
		40	1.25 - 5.6	68		
		45	1.25 - 5.6	120		
 Bevel-helical gear units	PLB	16	5.6 - 22.4	6	0.97	22
		20	5.6 - 22.4	11		
		25	5.6 - 22.4	18		
		31	5.6 - 22.4	33		
		40	5.6 - 22.4	62		
		45	5.6 - 22.4	113		

PB...

Powers and torques

i_N	n_1	n_2	PB					40	45
			16	20	25	31	31		
		[min ⁻¹]	Nominal power					P_N [kW]	
1.25	1500	1200	660	1450	2800	4100	On request	On request	
	1000	800	440	970	1850	2750			
	T_{2N} [kNm]		5.25	11.5	22.3	32.6			
1.4	1500	1070	620	1350	2600	3800			
	1000	715	410	900	1700	2500			
	T_{2N} [kNm]		5.53	12	23.2	33.9			
1.6	1500	940	570	1260	2400	3600			
	1000	625	380	840	1600	2400			
	T_{2N} [kNm]		5.81	12.8	24.4	36.7			
1.8	1500	835	530	1160	2200	3350			
	1000	555	350	770	1450	2250			
	T_{2N} [kNm]		6.07	13.3	25.2	38.4			
2	1500	750	460	1000	2200	3100			
	1000	500	310	670	1450	2000			
	T_{2N} [kNm]		5.86	12.7	28	39.5			
2.24	1500	670	420	920	2000	2800			
	1000	445	280	610	1350	1850			
	T_{2N} [kNm]		5.99	13.1	28.5	39.9			
2.5	1500	600	420	920	1850	2800			
	1000	400	280	610	1250	1850			
	T_{2N} [kNm]		6.69	14.6	29.4	44.6			
2.8	1500	535	350	780	1600	2400			
	1000	360	230	520	1050	1600			
	T_{2N} [kNm]		6.24	13.9	28.5	42.8			
3.15	1500	475	350	750	1300	2100			
	1000	315	230	500	850	1400			
	T_{2N} [kNm]		7.02	15	26.1	42.1			
3.55	1500	425	290	580	1150	1950			
	1000	280	190	390	750	1300			
	T_{2N} [kNm]		6.55	13.1	26	44.1			
4	1500	375	270	520	850	1500	2700	4700	
	1000	250	180	350	570	1000	1800	3100	
	T_{2N} [kNm]		6.88	13.2	21.6	38.2	68.8	120	
4.5	1500	335	230	460	770	1400	2300	4200	
	1000	220	150	310	510	950	1550	2800	
	T_{2N} [kNm]		6.59	13.2	22.1	40.1	65.6	120	
5	1500	300	180	360	640	1200	2000	3200	
	1000	200	120	240	420	800	1350	2100	
	T_{2N} [kNm]		5.73	11.5	20.4	38.2	63.7	102	
5.6	1500	270	170	320	590	1000	1800	3000	
	1000	180	110	210	390	650	1200	2000	
	T_{2N} [kNm]		6.06	11.4	21	35.7	63.7	106	

PB...

Thermal capacities

PB .. -R1							
v_w [m/s]	n_1 [min ⁻¹]	Size					
		16	20 ⁶⁾	25 ⁶⁾	31 ⁵⁾⁶⁾	40	45
P_{t0} [kW]							
0.5 ¹⁾	–	127	179	234	318	4)	
1.2 ²⁾	–	182	256	334	454		
4.0 ³⁾	–	237	333	434	590		
P_{t1} [kW]							
	1500	354	497	650	883 ⁵⁾	4)	
	1000	263	370	484	657 ⁵⁾		
P_{t3} [kW]							
0.5 ¹⁾	–	505	691	1053	1415	4)	
1.2 ²⁾	–	560	768	1153	1551		
4.0 ³⁾	–	615	845	1253	1687		
P_{t4} [kW]							
	1500	732	1009	1469	1979 ⁵⁾	4)	
	1000	545	882	1093	1472 ⁵⁾		
P_{t8} [kW]							
0.5 ¹⁾	–	618	842	1310	1758	4)	
1.2 ²⁾	–	657	896	1380	1854		
4.0 ³⁾	–	695	950	1450	1950		
P_{t9} [kW]							
	1500	777	1065	1602	2153 ⁵⁾	4)	
	1000	713	976	1485	1995 ⁵⁾		
⁵⁾ Values only for $i_N = 3.55 \dots 5.6$ P_{t1}, P_{t4}, P_{t9}							
⁶⁾ Values for ratios starting with following values i_N (for lower ratios please contact us) P_{t0}, P_{t3}							
0.5 ¹⁾		i_N	4	4	4		
1.2 ²⁾			2.5	2.5	2.5		
4.0 ³⁾			2.24	2.24	2.24		

v_w = Average air speed

- 1) Small closed room, little air movement
- 2) Large hall with free air movement
- 3) Constantly strong air movement
- 4) On request

P_{t0} : Without additional cooling

P_{t1} : With fan

P_{t3} : With cooling coil

P_{t4} : With fan and cooling coil

P_{t8} : With 2 cooling coils

P_{t9} : With fan and 2 cooling coils

Thermal Factor

ϑ_U [°C]	f_w				
	ED %				
	100	80	60	40	20
10	1.14	1.21	1.34	1.53	2.03
20	1.00	1.06	1.17	1.34	1.78
30	0.86	0.91	1.00	1.15	1.53
40	0.71	0.76	0.84	0.96	1.27
50	0.57	0.61	0.67	0.77	1.02

Utilization factor

f_A									
Charge P_e / P_N [%]									
20	30	40	50	60	70	80	90	100	
0.7	0.8	0.86	0.9	0.93	0.96	0.98	0.99	1	

Utilisation < 20%: question required

PB					
16	20	25	31	40	45
Housing surfaces [m²]					
1.45	2.03	2.65	3.61	4.95	6.70

PLB...

Powers and torques

i_N	n_1	n_2	PLB					
			16	20	25	31	40	45
			Nominal power P_N [kW]					
5.6	1500	270	160	314	555	956	1806	3169
	1000	180	107	209	370	638	1204	2113
	T_{2N} [kNm]		5.72	11.2	19.8	34.1	64.4	113
6.3	1500	240	138	274	471	835	1566	2817
	1000	160	92	183	314	557	1044	1878
	T_{2N} [kNm]		5.55	11	18.9	33.5	62.8	113
7.1	1500	211	110	221	403	726	1389	2256
	1000	141	73	147	268	484	926	1504
	T_{2N} [kNm]		4.96	10	18.2	32.8	62.8	102
8	1500	188	112	220	389	670	1264	2219
	1000	125	75	147	259	446	843	1479
	T_{2N} [kNm]		5.72	11.2	19.8	34.1	64.4	113
9	1500	167	97	192	330	585	1096	1972
	1000	111	65	128	220	390	731	1315
	T_{2N} [kNm]		5.55	11	18.9	33.5	62.8	113
10	1500	150	78	157	286	515	986	1602
	1000	100	52	105	191	343	658	1068
	T_{2N} [kNm]		4.96	10	18.2	32.8	62.8	102
11.2	1500	134	80	157	278	478	903	1585
	1000	89	53	105	185	319	602	1056
	T_{2N} [kNm]		5.72	11.2	19.8	34.1	64.4	113
12.5	1500	120	70	138	237	421	789	1420
	1000	80	46	92	158	281	526	947
	T_{2N} [kNm]		5.55	11	18.9	33.5	62.8	113
14	1500	107	56	112	204	368	705	1144
	1000	71	37	75	136	245	470	763
	T_{2N} [kNm]		4.96	10	18.2	32.8	62.8	102
16	1500	94	56	107	194	335	632	1109
	1000	63	37	71	130	223	421	740
	T_{2N} [kNm]		5.72	10.9	19.8	34.1	64.4	113
18	1500	83	48	96	165	292	548	986
	1000	56	32	64	110	195	365	657
	T_{2N} [kNm]		5.55	11	18.9	33.5	62.8	113
20	1500	75	39	79	143	258	493	801
	1000	50	26	52	95	172	329	534
	T_{2N} [kNm]		4.96	10	18.2	32.8	62.8	102
22.4	1500	67	37	70	128	220	423	743
	1000	44.5	25	47	85	147	282	496
	T_{2N} [kNm]		5.26	10	18.2	31.4	60.3	106

PLB...

Thermal capacities

PLB .. -R1								
v_w [m/s]	n_1 [min ⁻¹]	Size						
		16	20	25	31	40 ⁵⁾	45 ⁵⁾	
P_{t0} [kW]								
0.5 ¹⁾	–	42	60	94	127	175	237	
1.2 ²⁾	–	61	85	134	182	250	338	
4.0 ³⁾	–	79	111	174	236	325	439	
P_{t1} [kW]								
	1500	118	166	260	353	485	4)	
	1000	88	123	193	263	361		
P_{t3} [kW]								
0.5 ¹⁾	–	168	230	421	566	884	946	
1.2 ²⁾	–	187	256	461	620	959	1047	
4.0 ³⁾	–	205	282	501	675	1034	1148	
P_{t4} [kW]								
	1500	244	336	588	792	1194	4)	
	1000	214	294	521	702	1070		
⁵⁾ P_{t0}, P_{t3} Values for ratios starting with following values i_N (for lower ratios please contact us)								
0.5 ¹⁾						i_N	9	11.2
1.2 ²⁾							6.3	8

v_w = Average air speed

- 1) Small closed room, little air movement
- 2) Large hall with free air movement
- 3) Constantly strong air movement
- 4) On request

P_{t0} : Without additional cooling

P_{t1} : With fan

P_{t3} : With cooling coil

P_{t4} : With fan and cooling coil

P_{t8} : With 2 cooling coils

P_{t9} : With fan and 2 cooling coils

Thermal capacities of types PLB -S5 and -T6: on request

Thermal Factor

ϑ_U [°C]	f_w				
	ED %				
	100	80	60	40	20
10	1.14	1.21	1.34	1.53	2.03
20	1.00	1.06	1.17	1.34	1.78
30	0.86	0.91	1.00	1.15	1.53
40	0.71	0.76	0.84	0.96	1.27
50	0.57	0.61	0.67	0.77	1.02

Utilization factor

f_A									
Charge P_e / P_N [%]									
20	30	40	50	60	70	80	90	100	
0.7	0.8	0.86	0.9	0.93	0.96	0.98	0.99	1	

Utilisation < 20%: question required

PLB					
16	20	25	31	40	45
Housing surfaces [m²]					
1.45	2.03	2.65	3.61	4.95	6.70

PB, PLB

i_N	PB					
	16	20	25	31	40	45
1.25	1.26	1.26	1.27	1.25	1.25	1.25
1.4	1.41	1.41	1.43	1.40	1.40	1.40
1.6	1.59	1.59	1.62	1.57	1.57	1.57
1.8	1.80	1.80	1.83	1.77	1.77	1.77
2	2.00	2.00	2.00	2.00	2.00	2.00
2.24	2.29	2.29	2.29	2.27	2.27	2.27
2.5	2.50	2.50	2.45	2.48	2.48	2.48
2.8	2.83	2.83	2.78	2.79	2.79	2.79
3.15	3.12	3.12	3.19	3.18	3.18	3.18
3.55	3.60	3.60	3.47	3.50	3.50	3.50
4	4.00	4.00	4.08	4.07	4.07	4.07
4.5	4.46	4.46	4.58	4.54	4.54	4.54
5	5.00	5.07	5.07	4.94	5.00	5.07
5.6	5.50	5.69	5.69	5.63	5.50	5.69

i_N	PLB					
	16	20	25	31	40	45
5.6	5.57	5.57	5.68	5.67	5.67	5.67
6.3	6.21	6.21	6.38	6.32	6.32	6.32
7.1	6.96	7.06	7.06	6.89	6.96	7.06
8	8.0	8.0	8.15	8.14	8.14	8.14
9	8.92	8.92	9.17	9.08	9.08	9.08
10	10	10.1	10.1	9.89	10.0	10.1
11.2	11.1	11.1	11.4	11.3	11.3	11.3
12.5	12.4	12.4	12.8	12.6	12.6	12.6
14	13.9	14.1	14.1	13.8	13.9	14.1
16	16.0	16.0	16.3	16.3	16.3	16.3
18	17.9	17.9	18.3	18.2	18.2	18.2
20	20	20.3	20.3	19.8	20.0	20.3
22.4	22.0	22.8	22.8	22.5	22.0	22.8

 i_N : Nominal ratio

PB, PLB

i_N	PB					
	16	20	25	31	40	45
1.25	0.0844	0.2273	0.6569	1.6783	-	-
1.4	0.0750	0.2016	0.5811	1.4984	-	-
1.6	0.0667	0.1787	0.5140	1.3379	-	-
1.8	0.0593	0.1582	0.4539	1.1934	-	-
2	0.0558	0.1468	0.5036	1.3117	-	-
2.24	0.0493	0.1286	0.4177	1.1001	-	-
2.5	0.0468	0.1177	0.3798	0.9805	-	-
2.8	0.0398	0.1051	0.3207	0.8390	-	-
3.15	0.0354	0.0932	0.2678	0.7117	-	-
3.55	0.0245	0.0694	0.2207	0.5655	-	-
4	0.0211	0.0602	0.1776	0.4642	-	-
4.5	0.0181	0.0519	0.1521	0.4039	-	-
5	0.0154	0.0436	0.1333	0.3626	-	-
5.6	0.0135	0.0373	0.1150	0.3092	-	-

i_N	PLB					
	16	20	25	31	40	45
5.6	0.0578	0.1416	0.4041	1.0755	3.0317	7.5236
6.3	0.0563	0.1370	0.3906	1.0437	2.9479	7.3054
7.1	0.0546	0.1319	0.3793	1.0189	2.8761	7.0907
8	0.0320	0.0783	0.2228	0.5877	1.6859	4.0943
9	0.0313	0.0760	0.2162	0.5723	1.6453	3.9885
10	0.0305	0.0736	0.2107	0.5602	1.6105	3.8844
11.2	0.0186	0.0458	0.1303	0.3392	0.9723	2.3699
12.5	0.0182	0.0446	0.1269	0.3313	0.9514	2.3153
14	0.0178	0.0434	0.1240	0.3251	0.9335	2.2617
16	0.0106	0.0262	0.0742	0.1891	0.5427	1.3266
18	0.0104	0.0256	0.0725	0.1853	0.5325	1.3001
20	0.0102	0.0250	0.0712	0.1822	0.5238	1.2741
22.4	0.0101	0.0245	0.0700	0.1789	0.5172	1.2537

Mass moment of inertia in kgm²



BREVINI[®]

Motion Systems

Page intentionally left blank

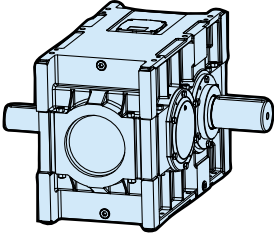
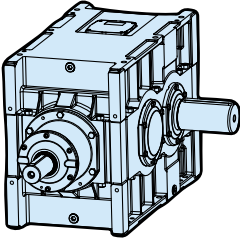
Type		Mounting position	
 <p>Helical gear units</p>	<p>PB</p>	<p>R1</p>	<p>30</p>
 <p>Bevel-helical gear units</p>	<p>PLB</p>	<p>R1</p>	<p>32</p>
		<p>S5</p>	<p>34</p>
		<p>T6</p>	<p>36</p>

R1 : Horizontal, output shaft horizontal
S5 : Vertical, output shaft below - on request
T6 : Vertical, output shaft above - on request

PB ... -R1

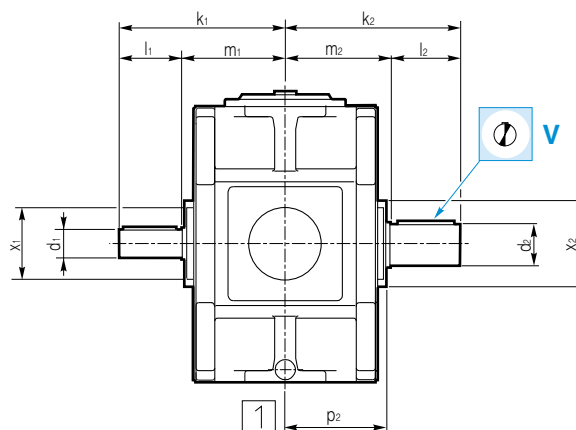
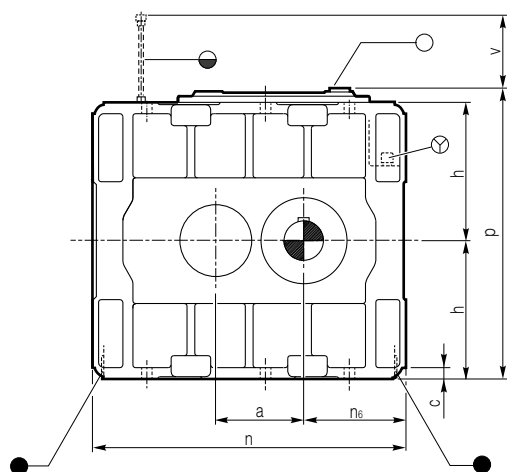
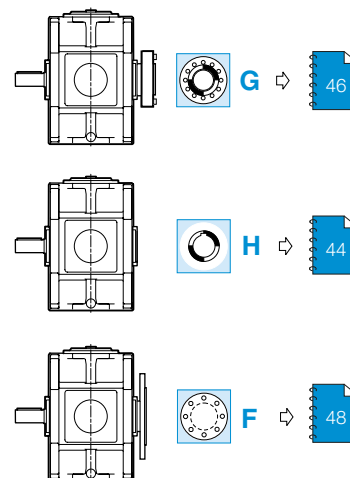
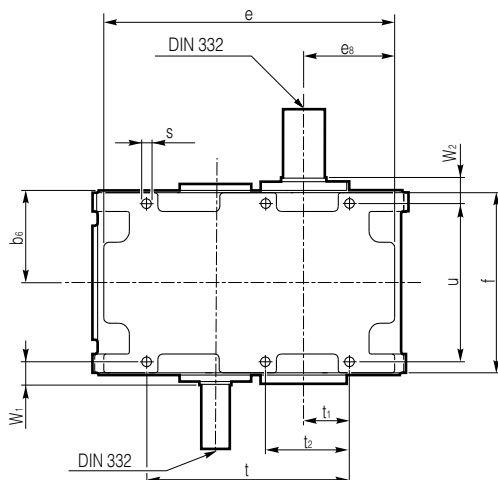

	Input shaft										Output shaft				
	i_N	$\varnothing d_1$	k_1	l_1	i_N	$\varnothing d_1$	k_1	l_1	m_1	$\varnothing x_1$	$\varnothing d_2$	k_2	l_2	m_2	$\varnothing x_2$
PB 16	1.25... 3.15	70 m6	338	145	3.55... 5.6	50 k6	318	125	193	205	80 m6	363	170	193	195
PB 20		80 m6	396	170		65 m6	371	145	226	235	95 m6	396	170	226	235
PB 25		100 m6	495	215		80 m6	450	170	280	295	120 m6	495	215	280	300
PB 31		130 m6	582	250		100 m6	547	215	332	368	140 m6	582	250	332	328
PB 40		160 m6	680	290		130 m6	640	250	390	440	165 m6	695	290	405	400
PB 45		180 m6	790	330		160 m6	750	290	460	540	185 m6	805	330	475	440



The other mounting positions S5, T6 are available on request.



PB ... -R1



	Casing										
	a	b ₆	c	e	e8	f	h -0.2	n	n ₆	p	p ₂
PB 16	164	179	22	556	179	348	265	600	201	560	190
PB 20	201	210	26	662	207	410	315	714	233	663	223
PB 25	247	225	28	772	251	438	375	824	277	787	269
PB 31	302	270	30	928	297	522	425	980	323	887	314
PB 40	374	325	35	968	303	630	450	1220	421	913	363
PB 45	449	395	45	1197	371	774	475	1494	515	962	440

	Fitting									 OIL [l]	
	Ø s	d _s x l _{max}	t	t ₁	t ₂	u	w ₁	w ₂	v		
PB 16	18.5	M16x110	396	99	–	306	40	40	415	20	270
PB 20	24	M20x130	461	104	–	360	46	46	495	40	430
PB 25	24	M20x160	574	152	–	388	86	86	590	70	750
PB 31	28	M24x180	716	191	315	468	98	98	690	120	1200
PB 40	28	M24x200	906	270	410	576	102	117	440	120	2000
PB 45	35	M30x160	1115	330	485	712	104	119	550	160	3250

Dimensions l, m. and w. for grease lubricated labyrinth seals, on request.

PLB ... -R1

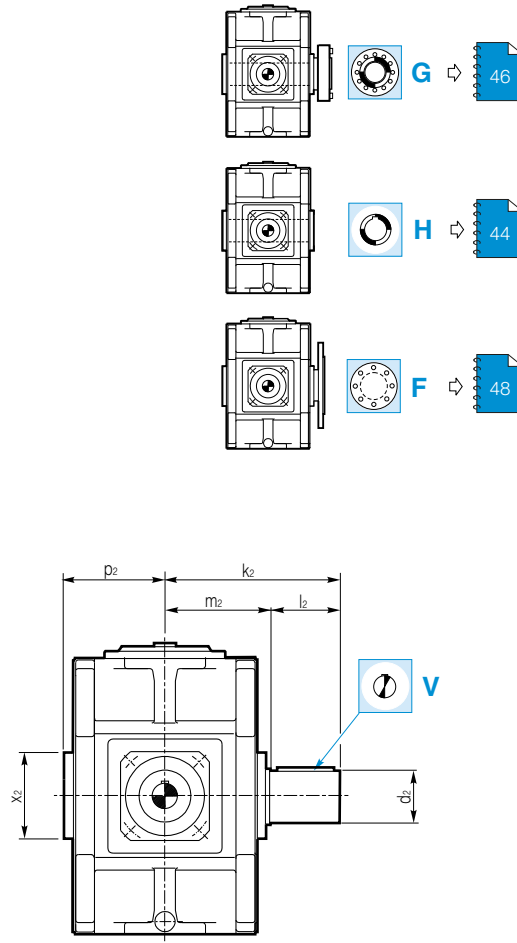
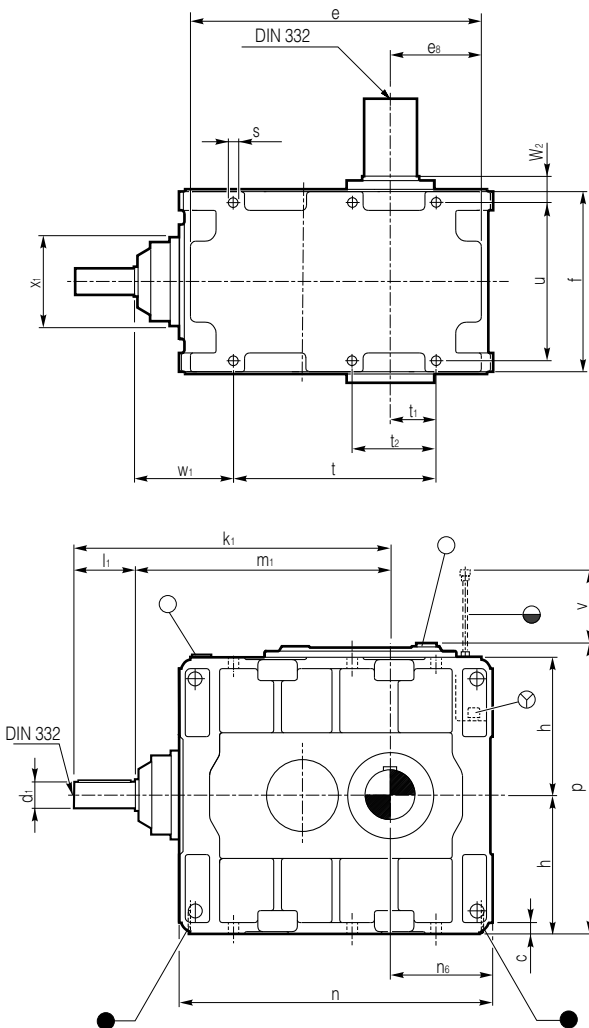



	Input shaft					Output shaft				
	Ø d ₁	k ₁	l ₁	m ₁	Ø x ₁	Ø d ₂	k ₂	l ₂	m ₂	Ø x ₂
PLB 16	50 k6	611	120	491	225	85 m6	356	145	211	–
PLB 20	60 m6	723	145	578	255	120 m6	433	190	243	–
PLB 25	75 m6	891	160	731	285	145 m6	495	230	265	296
PLB 31	85 m6	1064	180	884	350	160 m6	540	230	310	328
PLB 40	100 m6	1309	215	1094	440	155 m6	665	290	375	328
PLB 45	130 m6	1530	250	1280	540	195 m6	780	330	450	400

PLB ... -R1



	Casing								
	c	e	e ₈	f	h -0.2	n	n ₆	p	p ₂
PLB 16	22	556	179	348	265	600	201	560	–
PLB 20	26	662	207	410	315	714	233	663	–
PLB 25	28	772	251	438	375	824	277	787	256
PLB 31	30	928	297	522	425	980	323	887	302
PLB 40	35	1176	398	630	450	1220	421	913	357
PLB 45	45	1428	482	774	475	1494	515	962	432

	Fitting									 OIL [l]	
	∅ s	d _s x l _{max}	t	t ₁	t ₂	u	w ₁	w ₂	v		
PLB 16	18.5	M16x110	396	99	–	306	194	58	325	20	310
PLB 20	24	M20x130	461	104	–	360	221	63	375	40	500
PLB 25	24	M20x160	574	152	–	388	309	71	60	70	900
PLB 31	28	M24x180	716	191	315	468	359	76	100	120	1400
PLB 40	28	M24x220	906	270	410	576	458	87	250	150	2300
PLB 45	35	M30x160	1115	330	485	712	495	94	300	220	3900

Dimensions l, m. and w. for grease lubricated labyrinth seals, on request.

PLB ... -S5

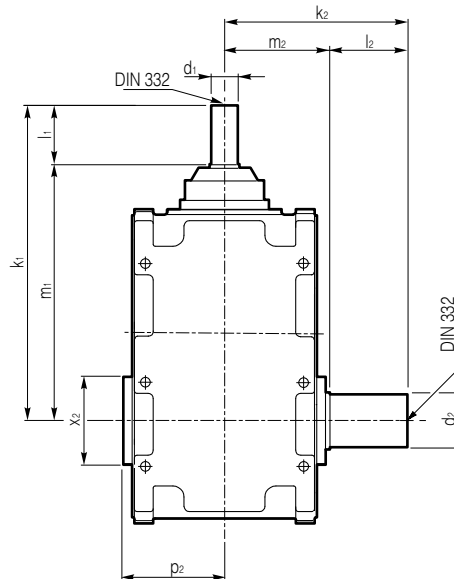
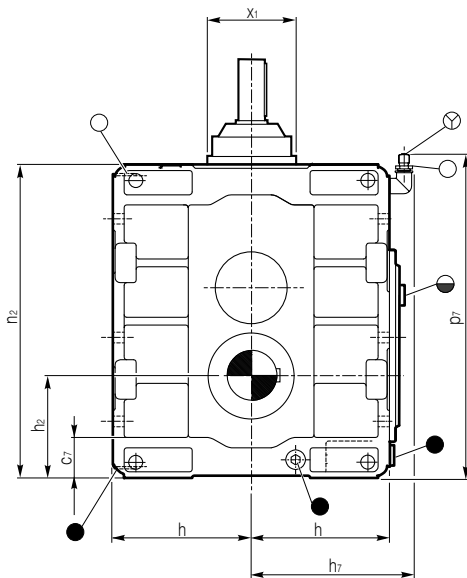
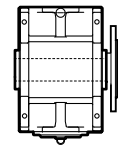
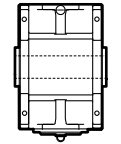
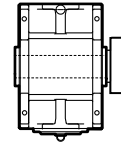
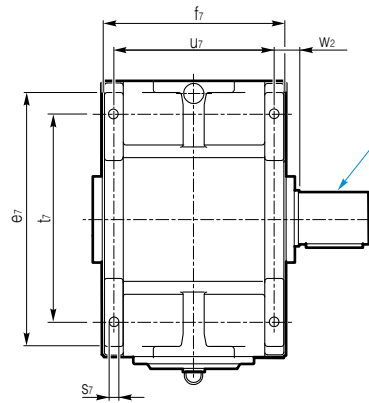
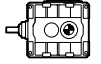



	Input shaft					Output shaft				
	$\varnothing d_1$	k_1	l_1	m_1	$\varnothing x_1$	$\varnothing d_2$	k_2	l_2	m_2	$\varnothing x_2$
PLB 16	50 k6	611	120	491	225	85 m6	356	145	211	–
PLB 20	60 m6	723	145	578	255	120 m6	433	190	243	–
PLB 25	75 m6	891	160	731	285	145 m6	495	230	265	296
PLB 31	85 m6	1064	180	884	350	160 m6	540	230	310	328
PLB 40 ... PLB 45	On request									

PLB ... -S5



	Casing								
	c ₇	e ₇	f ₇	h -0.2	h ₂ -0.2	h ₇	n ₂	p ₂	p ₇
PLB 16	75	486	348	265	201	322	600	–	633
PLB 20	92	578	410	315	233	372	714	–	740
PLB 25	93	698	438	375	277	432	824	256	852
PLB 31	97	798	522	425	323	493	980	302	1020
PLB 40 ... PLB 45	On request								

	Fitting					 OIL []	
	∅ s ₇	d _s x l _{max}	t ₇	u ₇	w ₂		
PLB 16	24	M20x130	384	312	55	28	310
PLB 20	28	M24x150	456	366	60	50	500
PLB 25	28	M24x180	578	396	67	74	900
PLB 31	28	M24x180	678	474	73	134	1400
PLB 40 ... PLB 45	On request						

Additional lubrication required, please check back.

Dimensions l, m. and w. for grease lubricated labyrinth seals, on request.

PLB ... -T6

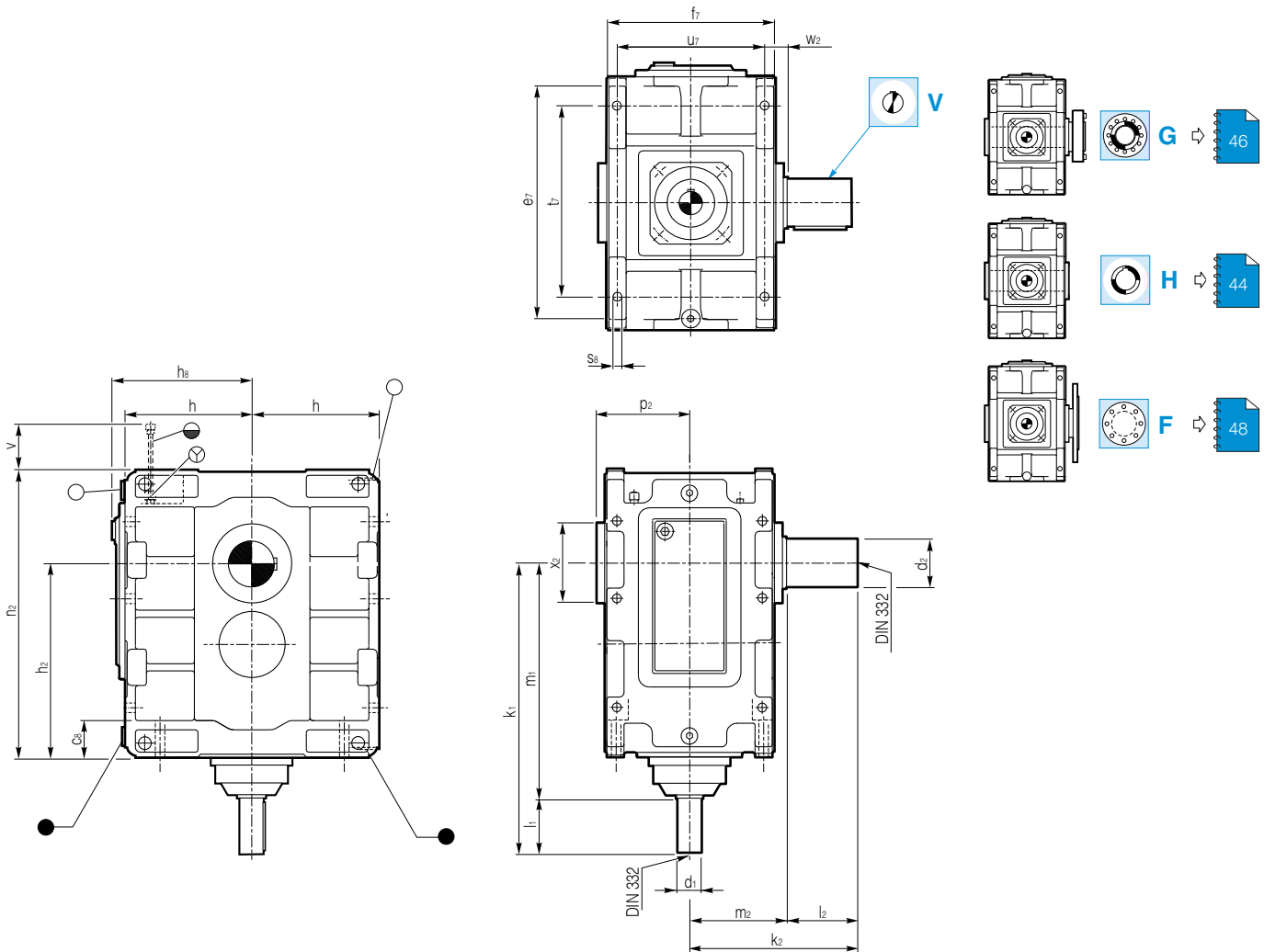
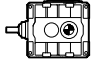











	Input shaft					Output shaft				
	$\varnothing d_1$	k_1	l_1	m_1	$\varnothing x_1$	$\varnothing d_2$	k_2	l_2	m_2	$\varnothing x_2$
PLB 16	50 k6	611	120	491	225	85 m6	356	145	211	-
PLB 20	60 m6	723	145	578	255	120 m6	433	190	243	-
PLB 25	75 m6	891	160	731	285	145 m6	495	230	265	296
PLB 31	85 m6	1064	180	884	350	160 m6	540	230	310	328
PLB 40 ... PLB 45	On request									

PLB ... -T6



	Casing							
	c_7	e_7	f_7	h -0.2	h_2 -0.2	h_3	n_2	p_2
PLB 16	75	486	348	265	399	295	600	–
PLB 20	92	578	410	315	481	348	714	–
PLB 25	93	698	438	375	547	412	824	256
PLB 31	97	798	522	425	657	462	980	302
PLB 40 ... PLB 45	On request							

	Fitting						 
	$\varnothing s_8$	$d_s \times l_{max}$	t_7	u_7	w_2	v	
PLB 16	24	M20x130	384	312	55	150	 
PLB 20	28	M24x150	456	366	60	165	 
PLB 25	28	M24x180	578	396	67	230	 
PLB 31	28	M24x180	678	474	73	275	 
PLB 40 ... PLB 45	On request						

Dimensions l , m , and w for grease lubricated labyrinth seals, on request.



BREVINI[®]

Motion Systems

Page intentionally left blank

PLB ... -R1

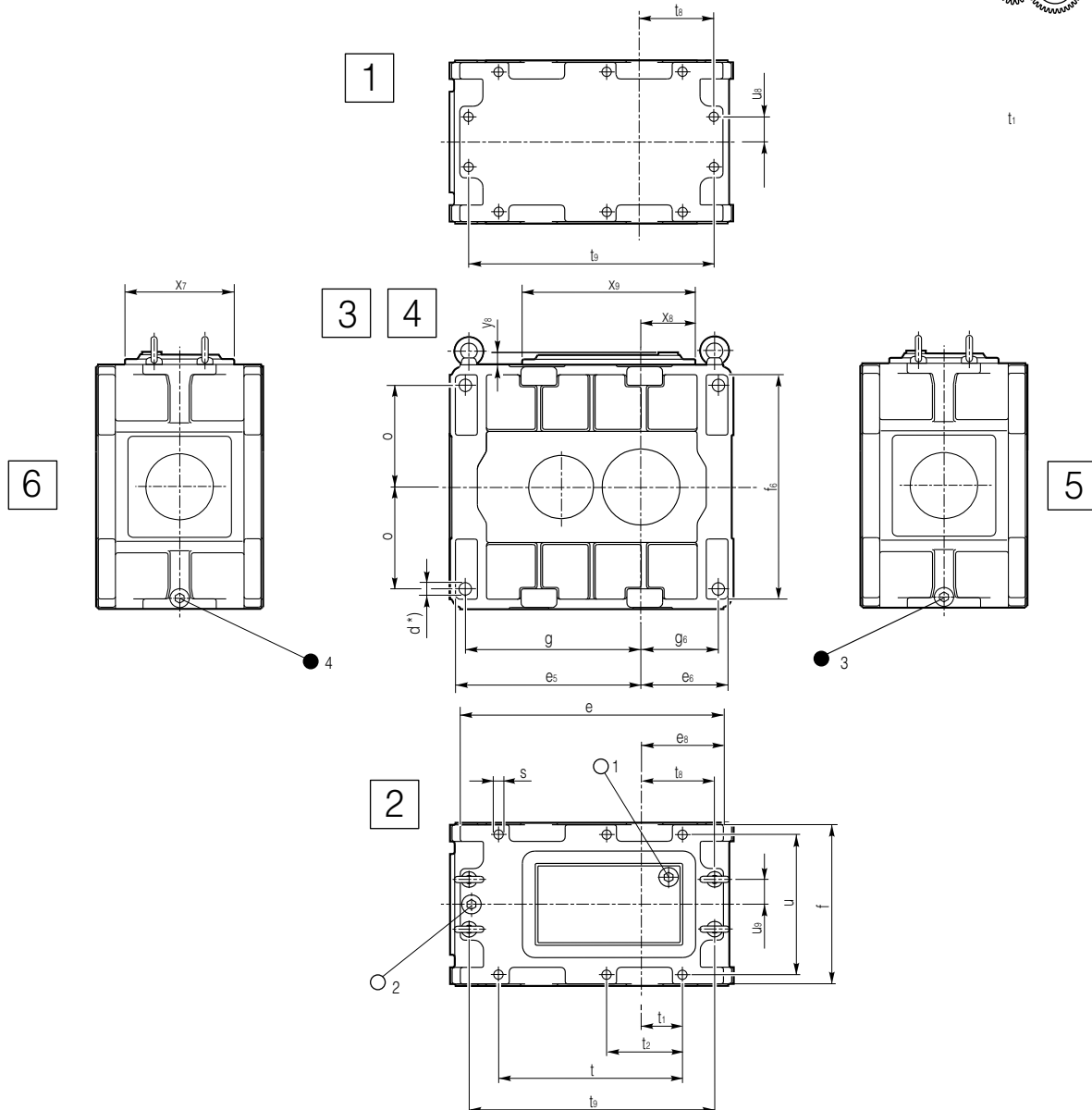

		Mounting surface															
		[1] + [2]											[2]				
		e	e _s	f	Ø s	d _s x l _{max}	t	t ₁	t ₂	t ₈	t ₉	u	U ₉	X ₇	X ₈	X ₉	Y ₈
PLB	16	556	179	348	18.5	M16x110	396	99	-	161	520	306	58	224	126	338	30
	20	662	207	410	24	M20x130	461	104	-	785	618	360	64	275	150	436	33
	25	772	251	438	24	M20x160	574	152	-	229	728	388	64	320	194	540	37
	31	928	297	522	28	M24x180	716	191	315	270	874	468	70	320	233	630	37

		Mounting surface													
		[3] + [4]									○1	○2	●3	●4	
		Ø d *)	d _s x l _{max}	T _A [Nm] *) 10.9	e ₅	e ₆	f ₆	g	g ₆	o					
PLB	16	26 H9	M24x100	950	388	190	486	368	170	220	G 1 1/4	G 1	G 1	G 1	
	20	33 H9	M30x120	1900	467	219	578	442	194	262					
	25	33 H9	M30x120	1900	533	263	698	508	238	322			G 1 1/4	G 1 1/4	G 1 1/4
	31	33 H9	M30x180	1900	643	309	798	618	284	373					

*) Necessary tightening torques T_A for shaft screws with head support according to DIN 912,934 etc., strenght category 10.9 with supposed coefficient of friction $\mu = 0,125$ for non treated, oiled screws according to the VDI directions 2230.

**) Threaded acc. to ISO 228

PLB ... -S5

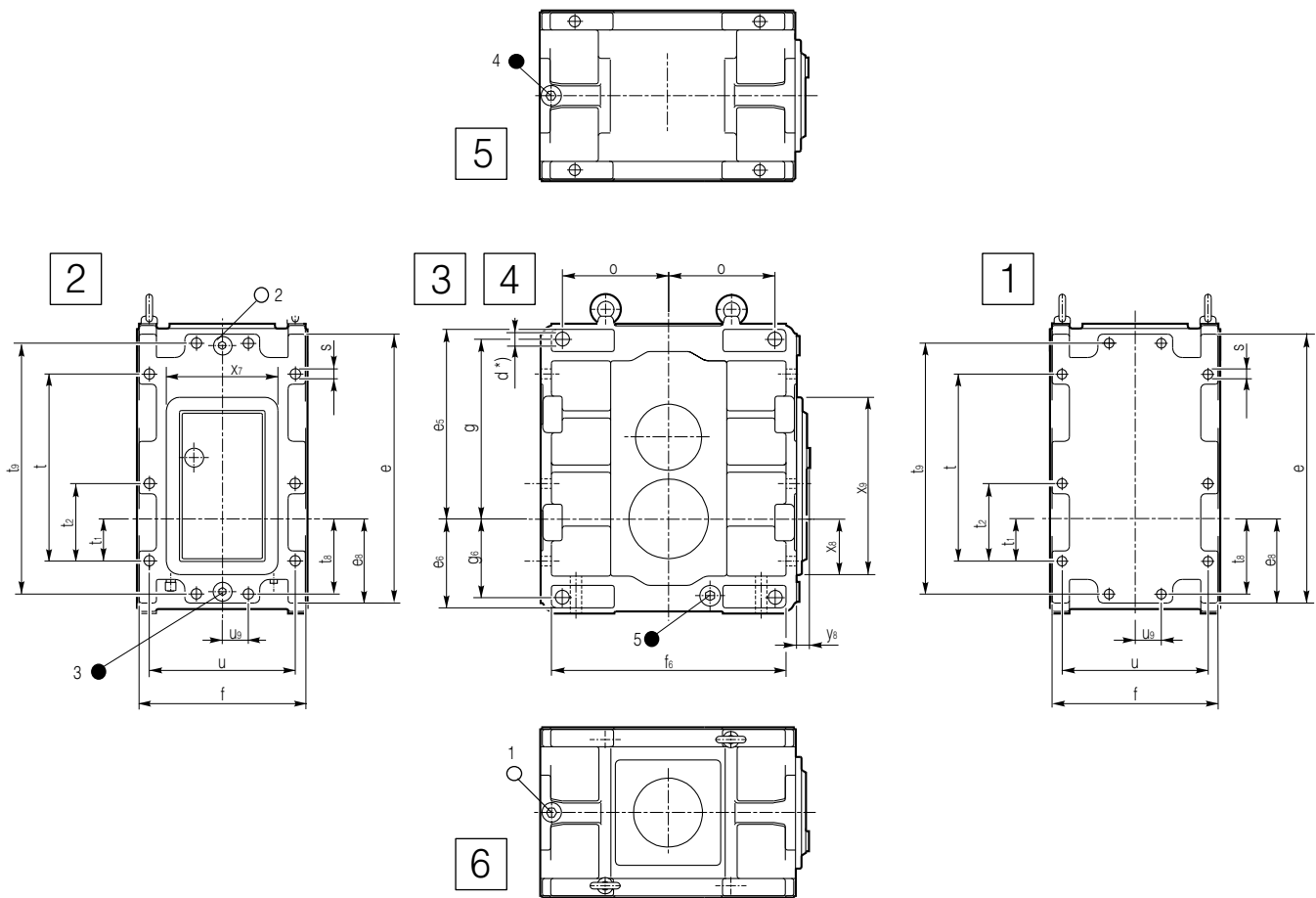

Mounting surface

		[1] + [2]												[2]			
		e	e ₈	f	Ø s	d _s x l _{max}	t	t ₁	t ₂	t ₈	t ₉	u	u ₉	x ₇	x ₈	x ₉	y ₈
PLB	16	556	179	348	18.5	M16x110	396	99	-	161	520	306	58	224	126	338	30
	20	662	207	410	24	M20x130	461	104	-	785	618	360	64	275	150	436	33
	25	772	251	438	24	M20x160	574	152	-	229	728	388	64	320	194	540	37
	31	928	297	522	28	M24x180	716	191	315	270	874	468	70	320	233	630	37

Mounting surface

		[3] + [4]									**)				
		Ø d	d _s x l _{max}	T _A [Nm] *) 10.9	e ₅	e ₆	f ₆	g	g ₆	o	○1	○2	●3	●4	●5
PLB	16	26 H9	M24x100	950	388	190	486	368	170	220	G 1	G 1	G 1	G 1	G 1
	20	33 H9	M30x120	1900	467	219	578	442	194	262					
	25	33 H9	M30x120	1900	533	263	698	508	238	322	G 1 1/4	G 1 1/4	G 1 1/4	G 1 1/4	G 1 1/4
	31	33 H9	M30x180	1900	643	309	798	618	284	373					

*) Necessary tightening torques T_A for shaft screws with head support according to DIN 912,934 etc., strength category 10.9 with supposed coefficient of friction $\mu = 0,125$ for non treated, oiled screws according to the VDI directions 2230.

**) Threaded acc. to ISO 228

PLB ... -T6

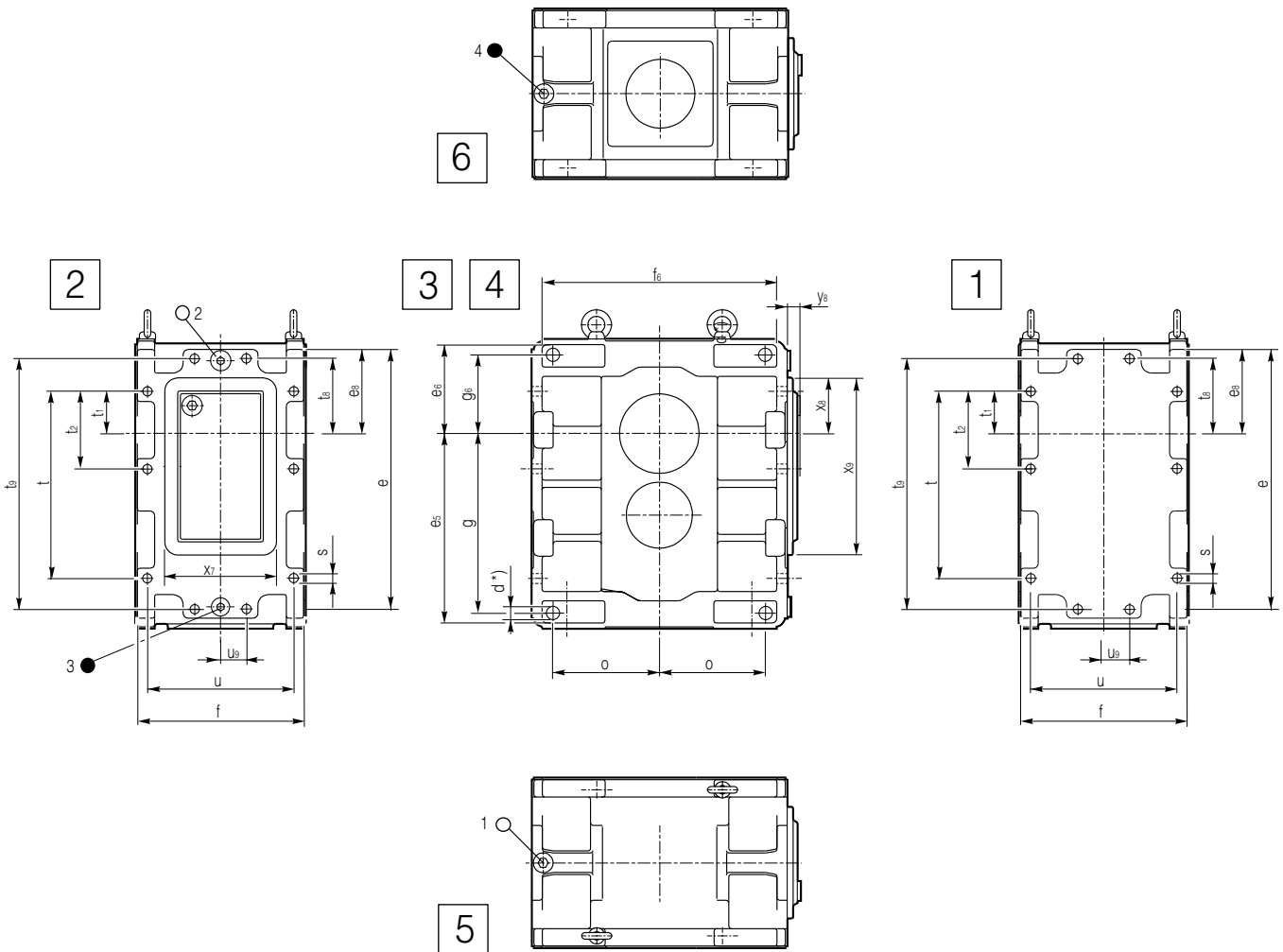

		Mounting surface															
		[1] + [2]												[2]			
		e	e ₈	f	Ø s	d _s x l _{max}	t	t ₁	t ₂	t _g	t ₉	u	u ₉	x ₇	x ₈	x ₉	y ₈
PLB	16	556	179	348	18.5	M16x110	396	99	-	161	520	306	58	224	126	338	30
	20	662	207	410	24	M20x130	461	104	-	785	618	360	64	275	150	436	33
	25	772	251	438	24	M20x160	574	152	-	229	728	388	64	320	194	540	37
	31	928	297	522	28	M24x180	716	191	315	270	874	468	70	320	233	630	37

		Mounting surface										**)			
		[3] + [4]													
		Ø d	d _s x l _{max}	T _A [Nm] *) 10.9	e ₅	e ₆	f ₆	g	g ₆	o	○1	○2	●3	●4	
PLB	16	26 H9	M24x100	950	388	190	486	368	170	220	G 1	G 1	G 1	G 1	
	20	33 H9	M30x120	1900	467	219	578	442	194	262					
	25	33 H9	M30x120	1900	533	263	698	508	238	322	G 1 1/4	G 1 1/4	G 1 1/4	G 1 1/4	
	31	33 H9	M30x180	1900	643	309	798	618	284	373					

*) Necessary tightening torques T_A for shaft screws with head support according to DIN 912,934 etc., strenght category 10.9 with supposed coefficient of friction $\mu = 0,125$ for non treated, oiled screws according to the VDI directions 2230.

**) Threaded acc. to ISO 228

K-PLB...

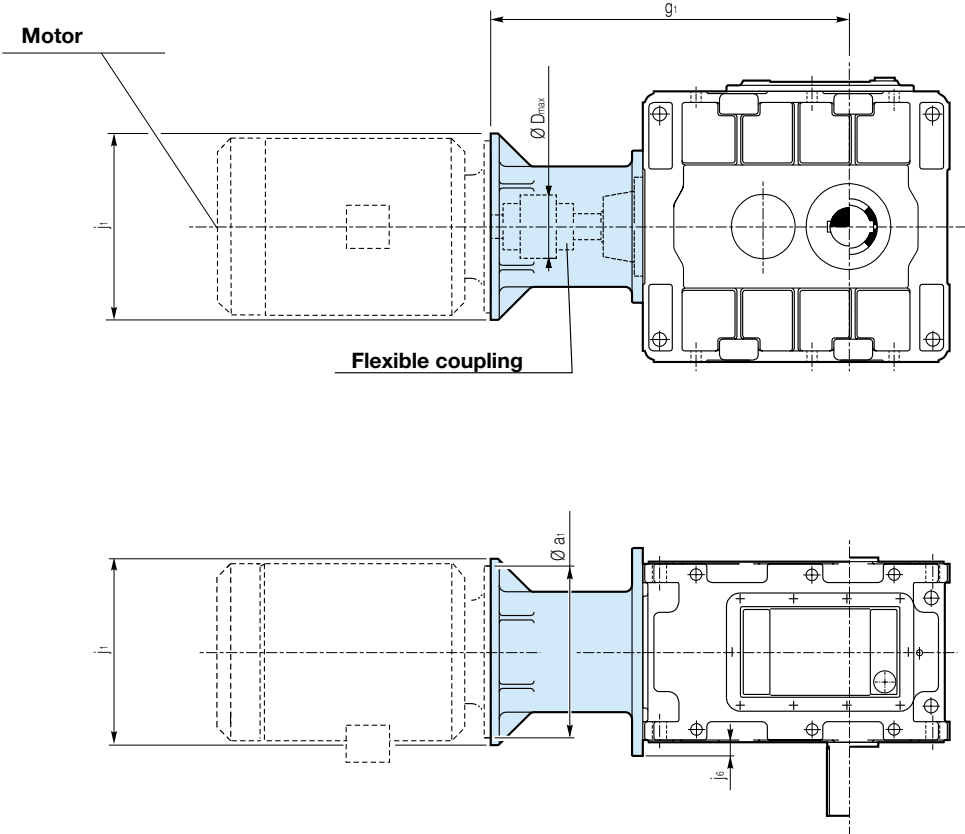

Motor bell housing available with or without motor. Appropriate flexible coupling is part of Dana supply.

K-PLB...



	Position of motor					Motor	
	R10	R11	**)				
	j ₆	j ₆	Ø D _{max}	g ₁	j ₁	IEC	Ø a ₁
16	23	—	250	868	Ø 660	315 M/S	660
				838	Ø 494	280 M/S	550
						250 M	
						225 M/S	450
				200 L	400		
			210	723	Ø 354	180 L/M	350
						160 L/M	
						*)	300
			778	Ø 300	*)	250	

				Motor		
	**)					
	Ø D _{max}	g ₁	j ₁	IEC	Ø a ₁	
20	250	950	Ø 660	315 M/S	660	
				280 M/S		550
		920	Ø 494	250 M		
				225 M/S	450	
	210	890	Ø 354	200 L	400	
				*)		350
		860	Ø 300	*)	300	
				*)	250	
25	360	1064	Ø 660	315 M/S	660	
				280 M/S		550
		1034	Ø 494	*)	450	
	*)			400		
	967	Ø 404	*)	350		
			360	1174	Ø 660	315 M/S
280 M/S						550
1144	Ø 494	*)		450		
		*)		400		
1077	Ø 404	*)	350			
		1177	Ø 404	*)	350	

*) Other motor bell housings available

***) Maximum diameter of coupling

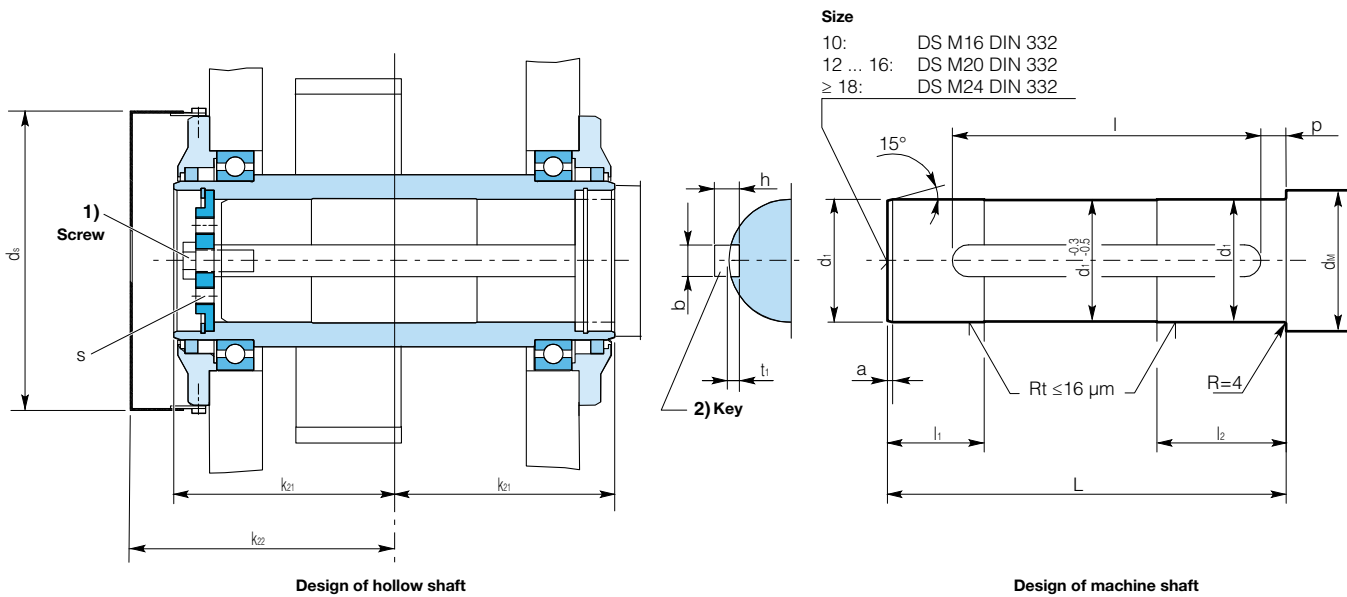

Key of machine shaft and secured screw 1) not to be supplied by Dana.
 Type of tolerance of the keyway width in the hollow shaft: P9.

		a	Ø d ₁	Ø d _{M min}	Ø d _s	k ₂₁	k ₂₂	l ₁	l ₂	L	l _{min}	p	t ₁	s	Screw 1) ISO4014	Key 2) b x h
PB, PLB	16	5	75 h6	96	230	189	206	60	82	347	180	18	7.5	M 12	M 20 x 55	20 x 12
	20	5	100 h6	120	282	220	236	80	109	402	220	24	10	M 16	M 24 x 70	28 x 16
	25	6	120 h6	140	308	265	297	95	123	492	280	22	11	M 16	M 24 x 70	32 x 18
	31	6	140 h6	160	338	310	354	110	149	573	320	29	12	M 20	M 24 x 70	36 x 20
	40	6	170 h6	190	380	380	412	135	180	705	400	35	13	M 20	M 24 x 70	40 x 22
	45	6	200 h6	220	470	445	605	160	215	825	400	40	15	M 20	M 24 x 70	40 x 25



H - Labyrinth

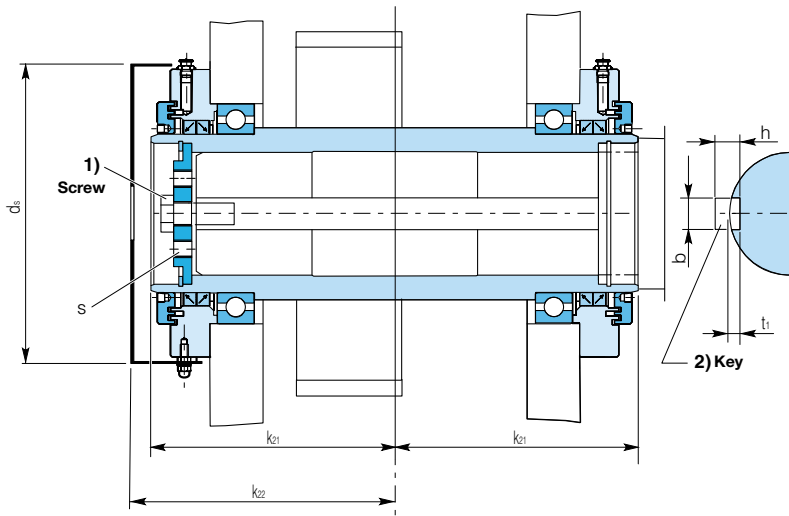

Design of hollow shaft

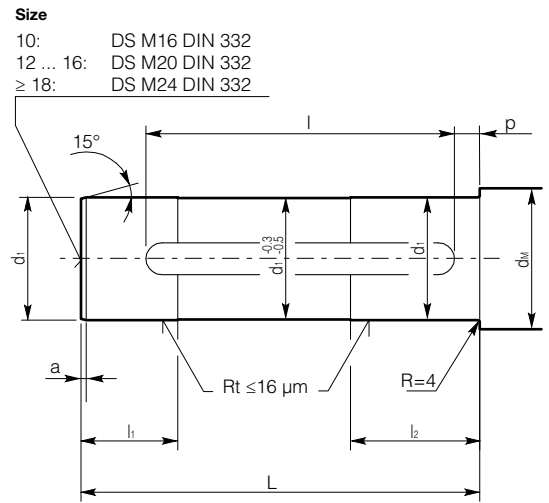

Design of machine shaft

Size
 10: DS M16 DIN 332
 12 ... 16: DS M20 DIN 332
 ≥ 18: DS M24 DIN 332

Key of machine shaft and secured screw 1) not to be supplied by Dana.
 Type of tolerance of the keyway width in the hollow shaft: P9.

		a	Ø d ₁	Ø d _{M min}	Ø d _s	k ₂₁	k ₂₂	l ₁	l ₂	L	l _{min}	p	t ₁	s	Screw 1) ISO4014	Key 2) b x h
PB, PLB	16	5	75 h6	96	200	236	305	60	82	441	180	18	7.5	M 12	M 20 x 55	20 x 12
	20	5	100 h6	120	250	268	350	80	109	498	220	24	10	M 16	M 24 x 70	28 x 16
	25	6	120 h6	140	310	281	295	95	123	524	280	22	11	M 16	M 24 x 70	32 x 18
	31	6	140 h6	160	340	340	350	110	149	633	320	29	12	M 20	M 24 x 70	36 x 20
	40	6	170 h6	190	380	400	430	135	180	745	400	35	13	M 20	M 24 x 70	40 x 22
	45	6	200 h6	220	470	445	605	160	215	825	400	40	15	M 20	M 24 x 70	40 x 25

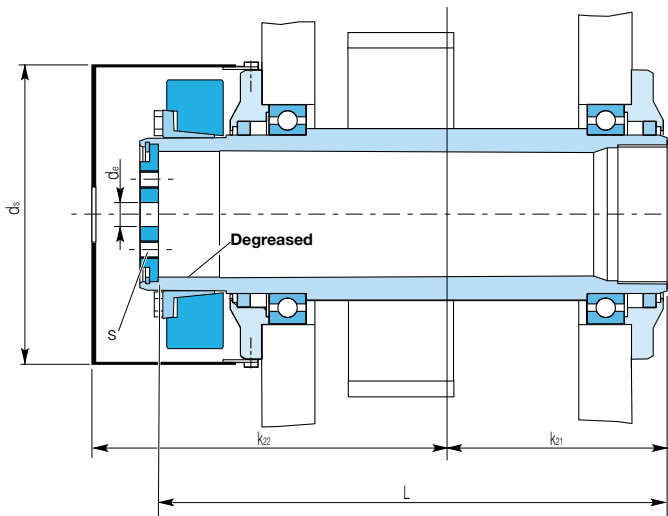

Mounting of shrink disc

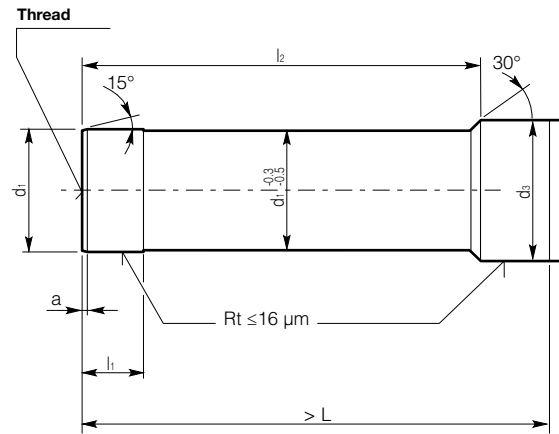

Design of machine shaft

Assembling and replacing the shrink disc according to instruction K 19776-BVK2.

1) Screw tightening torque.

	Type	Shrink disc				Hollow shaft						Machine shaft			
		Ø d	Screw ¹⁾	Ta ¹⁾ [Nm]	Ø d _s	k ₂₁	k ₂₂	Ø d _e	s	L	a	Ø d ₁	Ø d ₃	l ₁	l ₂
PB, PLB	16	100-81	M 10	70	200	189	263	23	M 12	422	5	80h6	80f6	44	385
	20	125-81	M 12	121	250	220	310	27	M 16	495	5	100h6	105f6	54	448
	25	155-81	M 14	193	315	265	365	27	M 16	599	6	120h6	130f6	64	543
	31	175-81	M 16	295	345	310	415	33	M 20	697	6	140h6	150f6	70	635
	40	220-71	M 16	250	385	380	525	33	M 20	867	6	170g6	180f6	104	770
	45	260-71	M 20	490	470	445	605	33	M 20	1010	6	210g6	220f6	120	900



G - Labyrinth

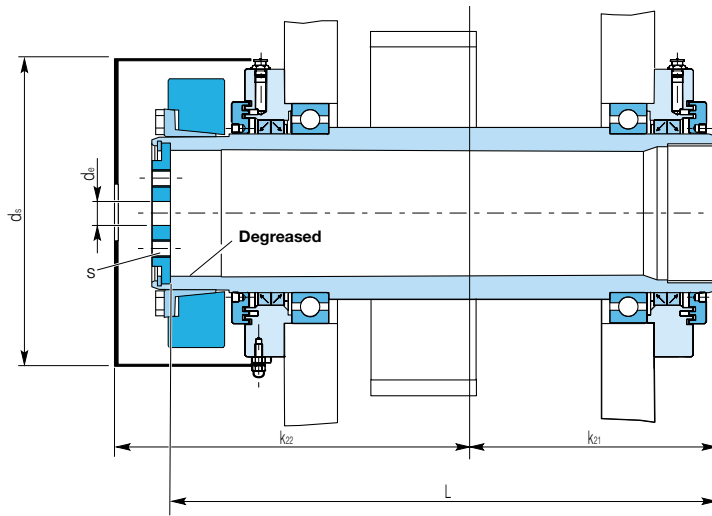

Mounting of shrink disc

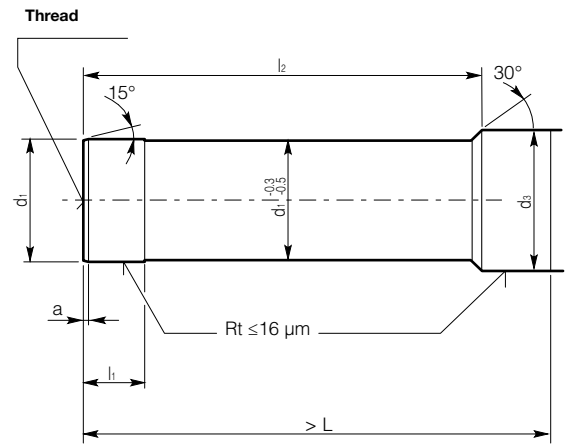

Design of machine shaft

Assembling and replacing the shrink disc according to instruction K 19776-BVK2.

1) Screw tightening torque.

		Shrink disc				Hollow shaft						Machine shaft				
		Type	Ø d	Screw ¹⁾	Ta ¹⁾ [Nm]	Ø d _s	k ₂₁	k ₂₂	Ø d _e	s	L	a	Ø d ₁	Ø d ₃	l ₁	l ₂
PB, PLB	16	100-81	100	M 10	70	200	236	305	23	M 12	518	5	80h6	80f6	45	481
	20	125-81	130	M 12	121	250	268	350	27	M 16	590	5	100h6	105f6	55	543
	25	155-81	160	M 14	193	315	281	385	27	M 16	631	6	120h6	130f6	65	575
	31	175-81	180	M 16	295	345	340	450	33	M 20	751	6	140h6	150f6	70	689
	40	220-71	220	M 16	250	385	400	540	33	M 20	900	6	170g6	180f6	105	805
	45	260-71	260	M 20	490	470	445	605	33	M 20	1010	6	210g6	220f6	120	900

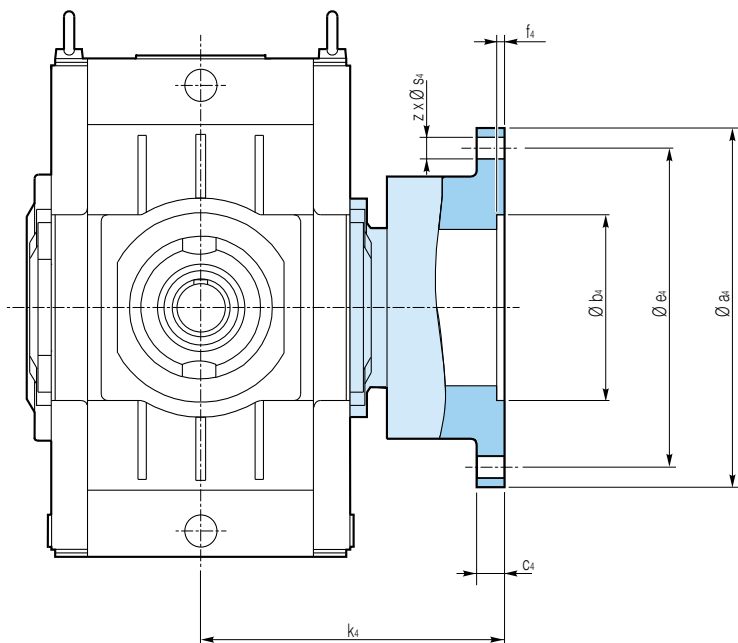

		k_4	a_4	e_4	b_4	f_4	c_4	z	s_4	Screw $\varnothing \times s_3$
PB, PLB	16	296	300	260	150 H7	10	25	16	22	M20x70
	20	338	320	280	160 H7	10	25	18	22	M20x70
	25	390	390	340	190 H7	10	30	18	26	M24x90
	31	447	430	380	220 H7	12	38	20	26	M24x100
	40	537	510	450	260 H7	12	42	18	33	M30x120
	45	644	620	540	310 H7	14	48	24	33	M30x130

PLB

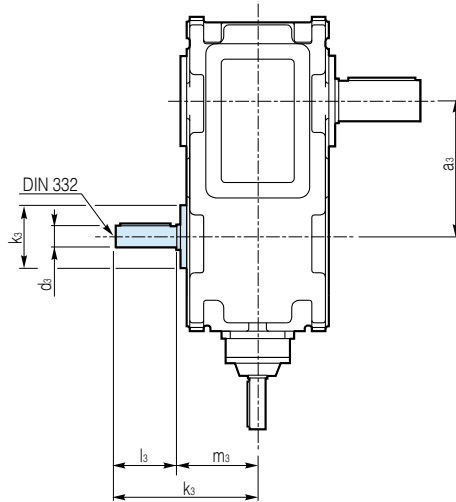

		a_3	$\varnothing d_3$	k_3	l_3	m_1	$\varnothing x_3$
PLB	16	164	60 m6	337	140	197	195
	20	201	70 m6	369	140	229	205
	25	247	90 m6	446	180	266	255
	31	302	100 m6	537	215	322	328
	40	374	120 m6	600	215	385	348
	45	449	150 m6	725	250	475	440



BREVINI[®]

Motion Systems

Page intentionally left blank

Type	 Page
Backstops	52
Torque reaction arms	53
Motor attachments	55
Fan cooling	56
Cooling coils	58
Heater	60
Sealing systems	61
Lubrication	62
Auxiliary drive	63
Breather with filter	64
Breather with wet filter	64
Temperature switch	64
Pressure switch	64
PT100	65
Manometer	65
Oil level switch	65
Oil drain with ball valve	65
Oil filter, single, double	66
Regulator for quantity of cooling water	66

PLB

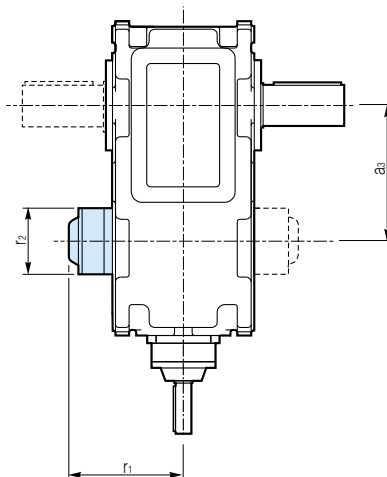

		r_1	$\varnothing r_2$	a_3
PLB *	16	275	175	164
	20	322	210	201
	25	372	250	247
	31	456	315	302
	40	520	342	374
	45	626	440	449

* Design with hollow shaft with backstop only from size ≥ 31

Directions of rotation and locations of shafts see page 9-10.
Backstops have adequate capacities to deal with full rated torque.

PB, PLB

Torque reaction arm with 1 ball-and-socket joint

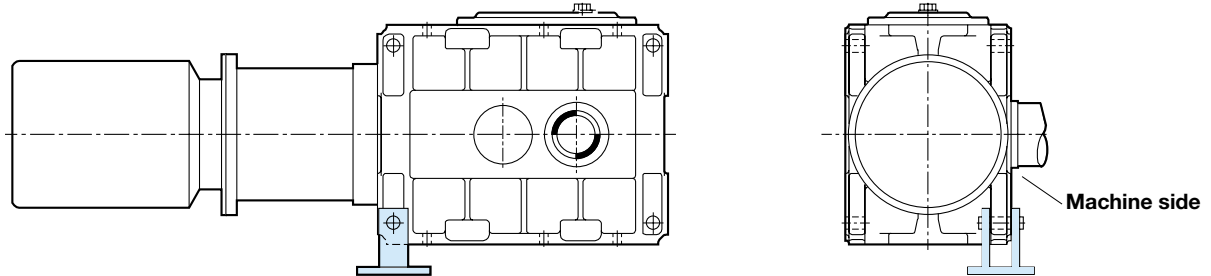

Torque arm on driven machine side

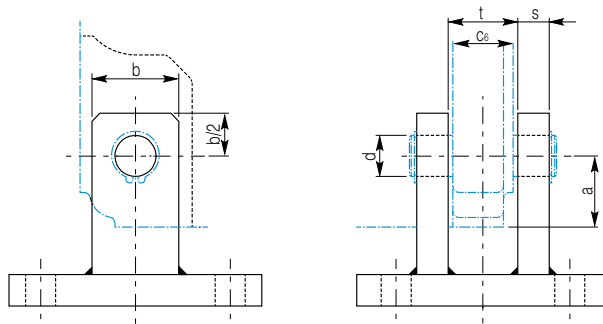

		a	t	c ₆	d	b	s
PB, PLB	16	45	45	41	26 H9/h6	55	20
	20	53	53	48	33 H9/h6	70	25
	25	53	53	48	33 H9/h6	70	25
	31	52	53	48	33 H9/h6	70	25
	40	50	68	62	45 H9/h6	110	35
	45	65	82	75	60 H9/h6	130	45

PB, PLB

Torque reaction arm with 2 ball-and-socket joints

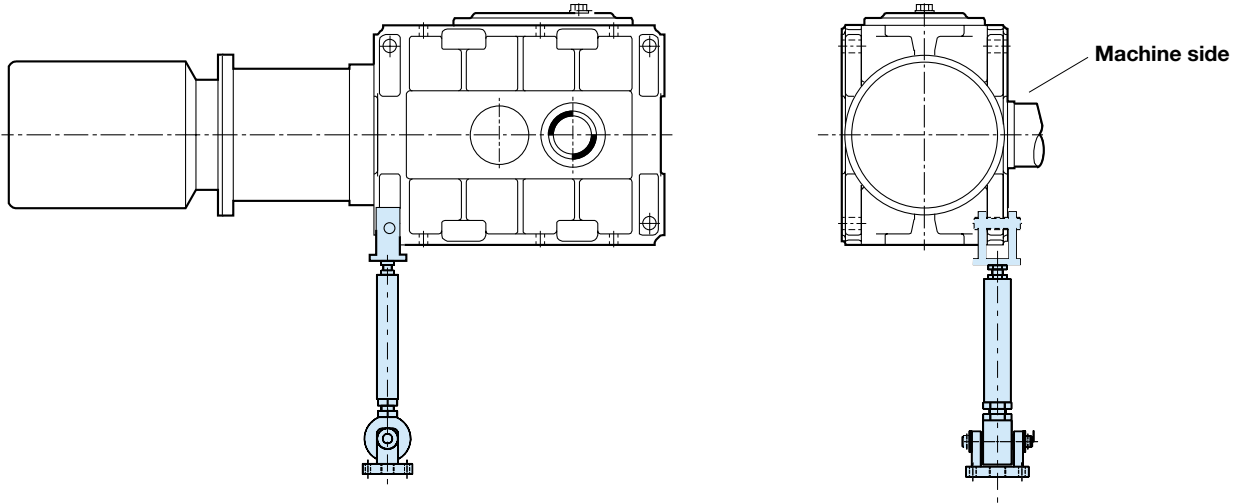

Dimensions on request

Torque reaction arm not supplied by Dana

J1-P...

Swing base

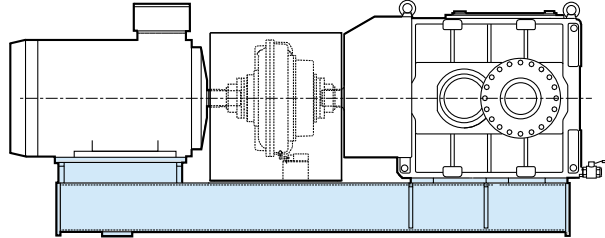

Dimensions on request

PB.. -R12

Permissible location of shafts .1 and .2 see page 8

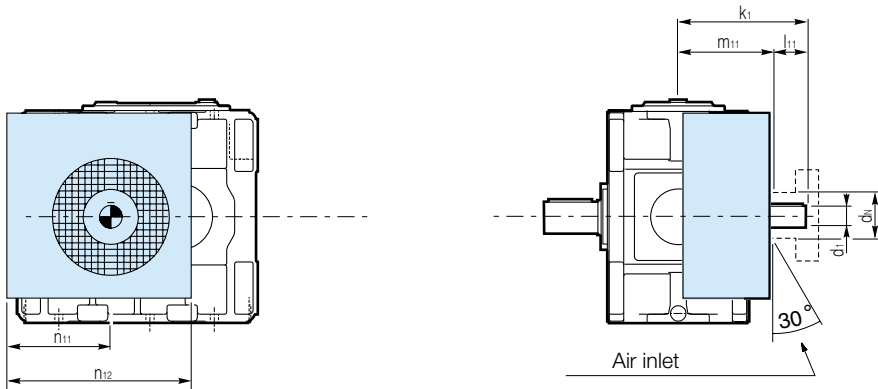

Attention: To mount the feet- fitting screws, demount the fan cover. Mounting of the input hub only after mounting of the feet-fitting screws.

		d ₁ ¹⁾		d _{N max}	k ₁	l ₁₁	m ₁₁	n ₁₁	n ₁₂
PB	16	70 m6	-	140	338	105	233	257	644
		-	50 k6	140	318	85	233	257	
	20	80 m6	-	180	396	130	266	303	759
		-	65 m6	180	371	105	266	303	
	25	100 m6	-	180	495	175	320	323	870
		-	80 m6	180	450	130	320	323	
	31 ²⁾	130 m6	-						1026
		-	100 m6	180	547	175	372	378	
	40,...45 ²⁾								

1) According to ratio

2) On request

PLB .. -R11

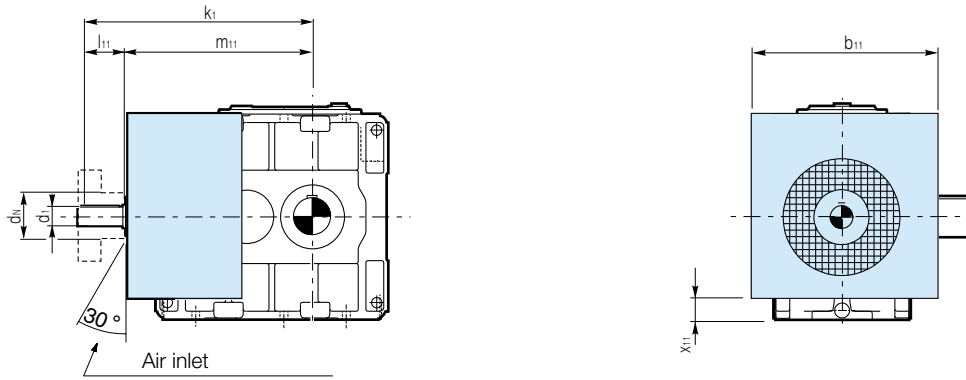

		b_{11}	d_1	$d_{N \max}$	k_1	l_{11}	m_{11}	x_{11}
PLB	16	380	50 k6	140	611	80	531	59
	20	440	60 m6	140	723	105	618	89
	25	468	75 m6	150	891	120	771	94
	31	548	85 m6	180	1064	140	924	94
	40	660	100 m6	180	1309	175	1134	150
	40,...45	On request						

PB

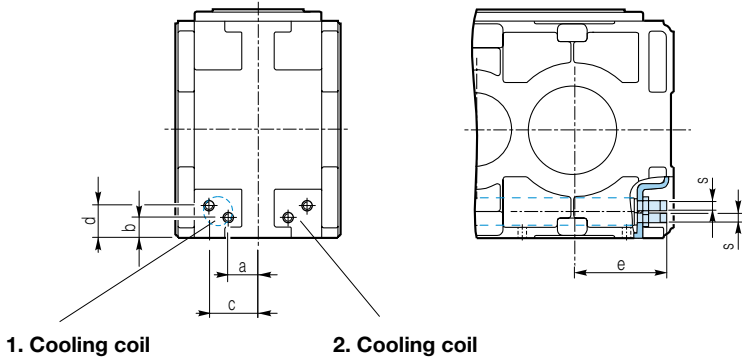

Water connection for cooling coil **without** cooling water controller

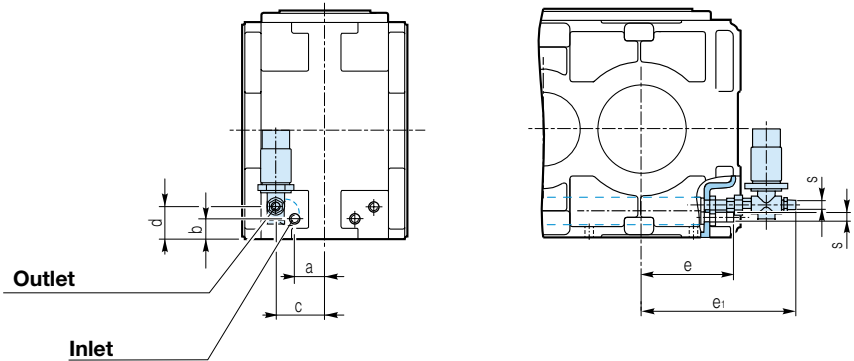

Water connection for cooling coil **with** cooling water controller

Water connections by the output side, optionally 1 or 2 cooling coils

		a	b	c	d	e	e ₁	s	V Water l/min	Δ p W bar
PB	16	56	45	82	110	196	332	R 1/2 A	12	0.55
	20	58	58	116	98	211	347	R 1/2 A		0.75
	25	54	55	118	118	255	391	R 1/2 A		0.4
	31	68	55	127	123	298	434	R 1/2 A		0.5
	40, 45	On request								

PLB

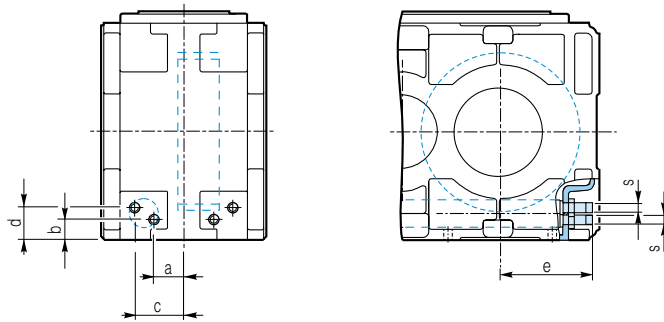

Water connection for cooling coil **without** cooling water controller

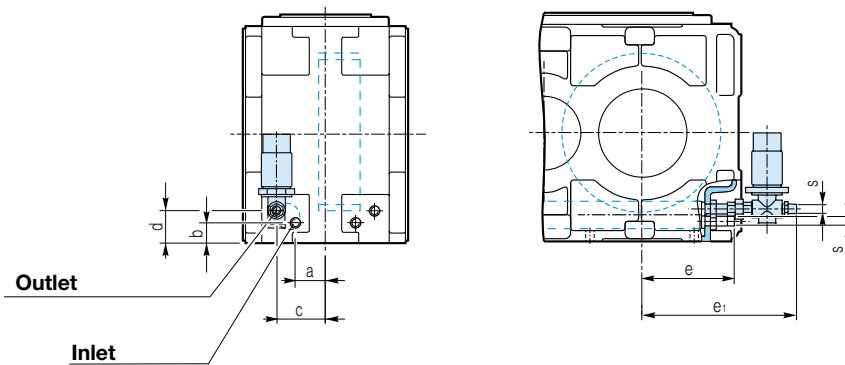

Water connection for cooling coil **with** cooling water controller

Cooling coil placed adjacent to the final gear wheel.
For the gear wheel position see the dimension sheets.

		a	b	c	d	e	e ₁	s	V Water l/min	Δ p W bar
PLB	16	55	48	76	115	193	329	R 1/2 A	12	0.55
	20	58	58	116	98	208	344	R 1/2 A		0.75
	25	54	55	118	118	250	386	R 1/2 A		0.4
	31	68	55	127	123	293	429	R 1/2 A		0.5
	40	94	117	204	117	372	511	R 3/4 A	18	0.6
	45	156	120	266	120	440	579	R 3/4 A		0.6

PB, PLB

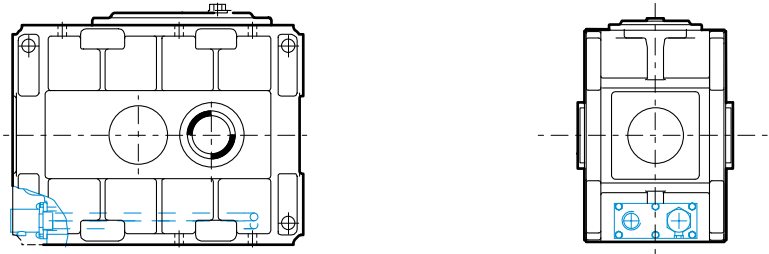

PB, PLB

Standard sealing

Single shaft seal with dust lip

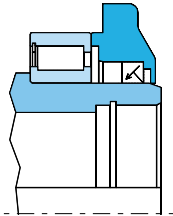

Hollow shaft

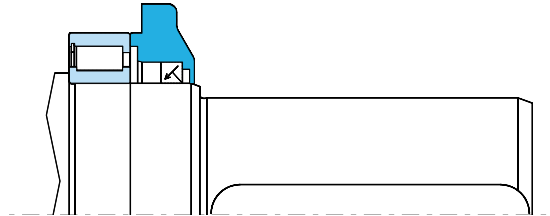

Solid shaft

Special seals according to the operating conditions

Two shaft seals, outside with dust lip

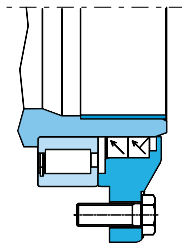

Hollow shaft

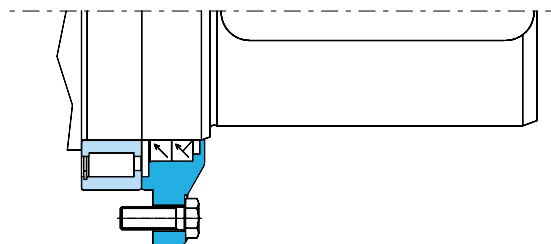

Solid shaft

Two shaft seals with additional refillable grased labyrinth seals (Taconite sealing)

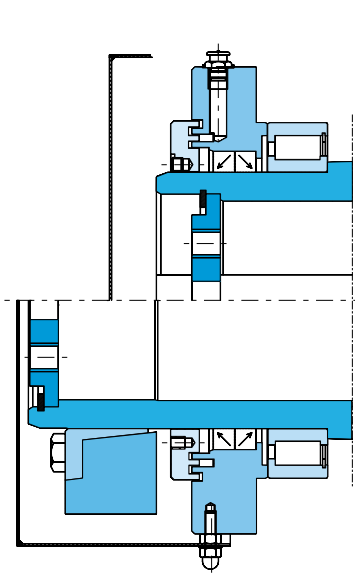

Hollow shaft

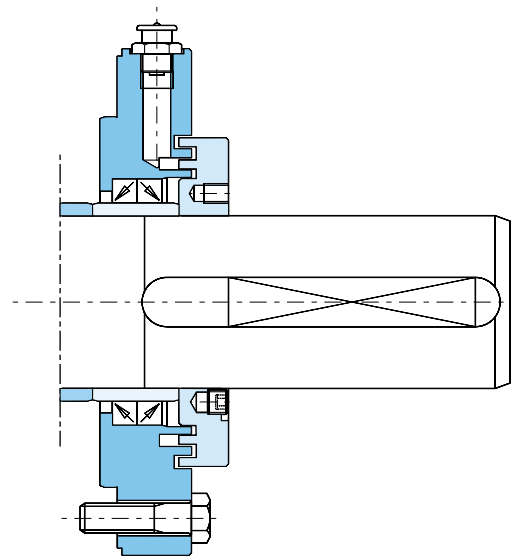

Solid shaft

PB, PLB .. -R1

Flange pump

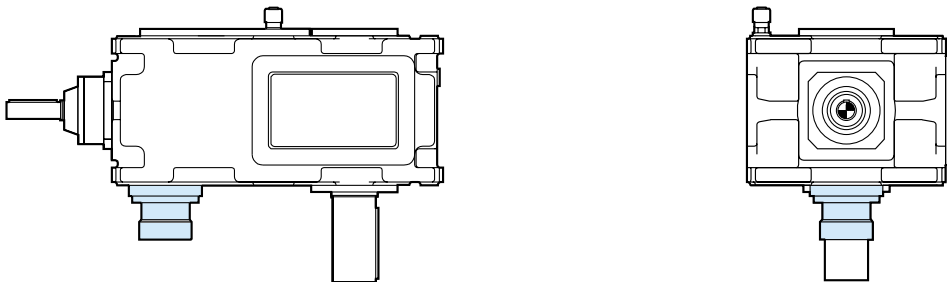

Motor pump

a) With pressure lubrication (motor pump)

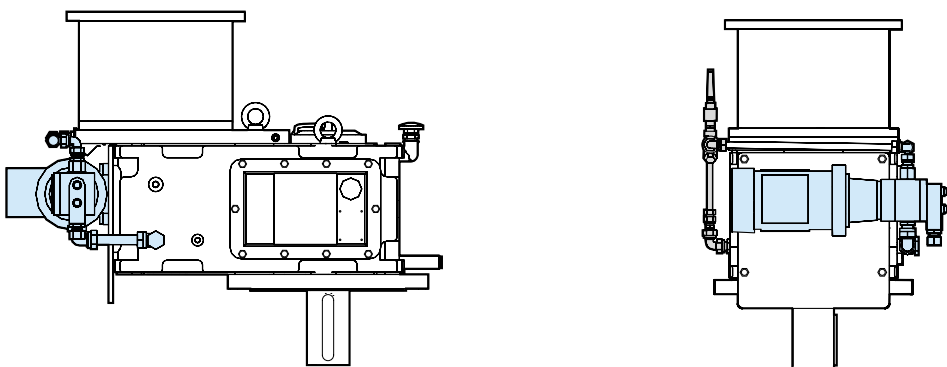

b) With pressure lubrication (motor pump) and plate cooler

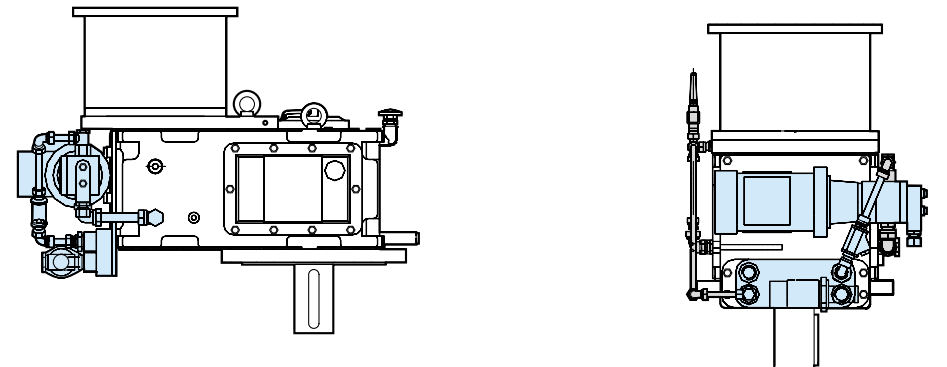

Separate cooling and lubrication system

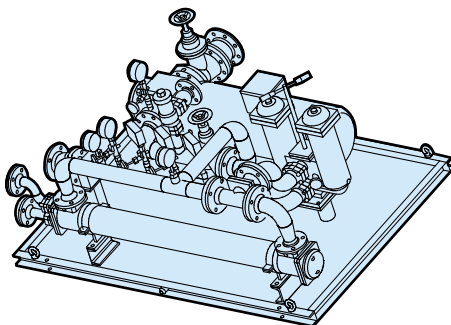

Dimensions on request



PB, PLB

F = Free-wheel

R = Backstop

The elements R and F are located in closed casings and are lubricated by the gearing oil

Version A

To avoid a turn back of the installation, the auxiliary drive must possess a motor-brake

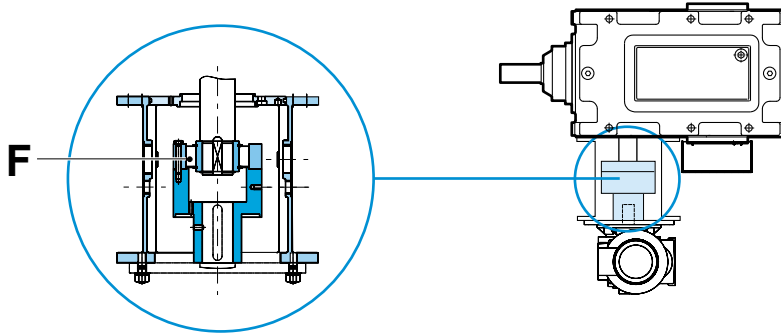

Version B

Standard execution

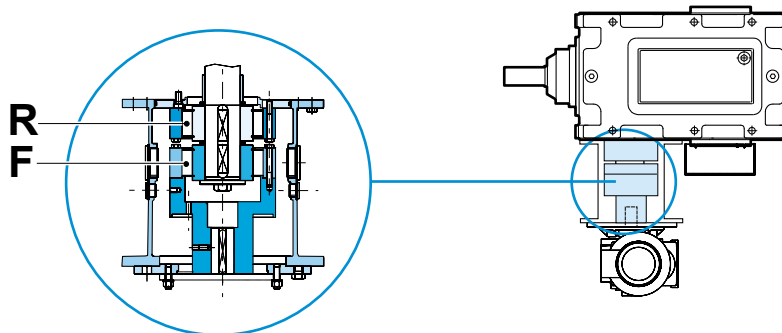

Version C

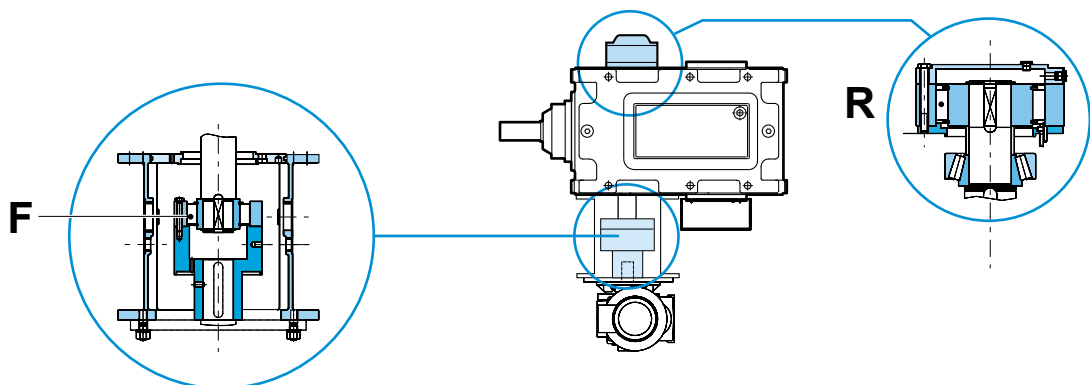

PB, PLB

**Breather with filter**

A breather with a filter can be used to prevent dust from entering the gearbox while the gear unit is cooling down.

**Breather with wet filter**

If the humidity is high, we recommend a breather with wet filter to prevent water vapor from penetrating the gear oil.

**Temperature switch**

To control the max. oil temperature there is the possibility to install a Temperature switch into the oil sump and get output signal when the temperature is above certain level.

**Pressure switch**

In case of a force lubrication or cooling unit there is the possibility to control the oil pressure with a pressure switch. If the oil pressure is below certain pressure a signal will stop the main motor of the gearbox.

PB, PLB



PT100

To monitor the oil temperatures on the gearbox, and set up different level of attention at certain temperature, for instance start, alert and stop of the gearbox.



Manometer

In case of a force lubrication or cooling unit there is the possibility to have visual control the oil pressure with a manometer.



Oil level switch

With the oil level switch is it possible to control the min. oil level of the gearbox in case you use a heater.



Oil drain with ball valve

For an easy, safe and clean oil drain from the gearbox, we can deliver an oil drain with a ball valve

PB, PLB

**Oil filter, single, double**

To increase the bearing lifetime is it possible in case of force lubrication / cooling to use an oil filter. We recommend a double switching filter for 24 hours operation.

**Regulator for quantity of cooling water**

In order to have a constant gear oil temperature with water cooling, we recommend the installation of a water regulator.



BREVINI[®]

Motion Systems

Page intentionally left blank





Brevini EvoMax™

The Brevini EvoMax™ gearbox series is a further development of the POSIRED 2 series from PIV Drives GmbH. The development has incorporated over 90 years of application knowledge and customer feedback and the outcome is a series of highly reliable, efficient and economical products.

The development of the Brevini EvoMax™ gearbox series enabled the improvement in torque density, smaller physical envelope, higher efficiency, lower weight, noise and power consumption. Overall, the modular design of the Brevini EvoMax™ series gives sustainable and efficient transmission that minimize operating costs and maximize availability.

Torque range 10 kNm up to 290kNm

Ratios from 4 up to 500

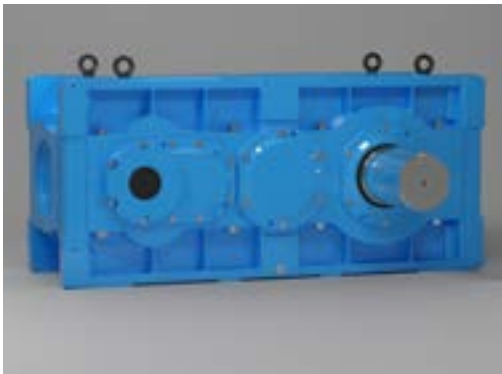

Brevini Posired 2 Big sizes

The Posired 2 is a bevel-helical gearbox series with 2, 3 and 4 helical bevel helical gear stages. The gearbox based on the modular system of Brevini EvoMax™ .

Torque range from 340 kNm up to 805 kNm.

Ratios up to 560.



High Power

The High Power is a compact bevel-helical gearbox with a planetary gearbox on the output.

Torque range from 90 kNm up to 2.100 kNm

Ratios up to 8.000



POSIRED N

The POSIRED N is a helical gearbox with an extended center distance.

Torque range 8 kNm up to 290 kNm

Ratios from 12,5 up to 500



POSIRED TS

The POSIRED TS is a helical gearbox with two counter-rotating output shafts.

Torque range 1 kNm up to 110 kNm

Ratios from 5 up to 100

	SI system into Imperial System	Imperial System into SI System
Power rating	kW x 1.341 = HP	HP x 0.7457 = kW
Torque	Nm x 8.851 = in-lbs Nm x 0.7375 = ft-lbs	in-lbs x 0.113 = Nm ft-lbs x 1.356 = Nm
Force	N x 0.2248 = lbs	lbs x 4.4482 = N
Stress	N/mm ² x 0.00689 = lbs/in ² (psi)	lbs/in ² x 145.04 = N/mm ²
Mass moment of inertia	kgm ² x 23.73 = lb-ft ²	lb-ft ² (psi) x 0.0421 = kgm ²
Lenght	mm x 0.03937 = inches m x 39.3701 = inches m x 3.2808 = foot µm x 0.03937 = mil (0.001 in)	inches x 25.4 = mm inches x 0.0254 = m foot x 0.3048 = m mil (0.001 in) x 25.4 = µm
Weight (mass)	kg x 2.205 = lbs	lbs x 0.4536 = kg
Volume	l x 0.264 = US gal	US gal x 3.785 = l
Volume flow rate	l/min x 0.264 = gal/min (GPM) m ³ /h x 0.2271 = gal/min (GPM)	gal/min (GPM) x 3.785 = l/min gal/min (GPM) x 4.403 = m ³ /h
Velocity	m/s x 196.85 = ft/min	ft/min x 0.0051 = m/s

Symbol	Name	Symbol	Name	Approximate temperature	
				°C	deg F
Nm	Newton-Meter	in-lbs	inch pounds	20	68
N/mm ²	Newton/Millimeter ²	ft-lbs	foot pounds	27	80
kgm ²	Kilogramm-Meter ²	lbs/in ² (psi)	pounds/inch ²	38	100
m	Meter	in	inches	-18	0
mm	Millimeter (0.001 Meter)	ft	foot	-12	10
µm	Mikrometer (0.001 Millimeter)	mil	0.001 inch	-7	20
kg	Kilogramm	lbs	pounds	0	32
kW	Kilowatt	HP	horsepower	4	40
N	Newton			15	60
l	Liter	lb-ft ²	pound foot ²	49	120
l/min	Liter/Minute	US gal	US gallons	60	140
m ³ /h	Meter ³ /Stunde	gal/min (GPM)	gallons/minute	77	170
m/s	Meter/Sekunde	ft/min	foot/minute	93	200

Torque calculation			
SI system		Imperial System	
$T = 9550 \times \frac{P}{n}$ [Nm]	P in kW n in min ⁻¹	$T = 5252 \times \frac{P}{n}$ [ft-lbs] $T = 63025 \times \frac{P}{n}$ [in-lbs]	P in HP n in rpm
$T = 159.2 \times \frac{P}{n}$ [Nm]	P in kW n in 1/s	$T = 87.53 \times \frac{P}{n}$ [ft-lbs] $T = 1050.42 \times \frac{P}{n}$ [in-lbs]	P in HP n in rps

© 2023 Dana Limited. All rights reserved.

The reproduction, distribution and utilization of this document as well as the communication of its contents to others without explicit authorization is prohibited.

Offenders will be held liable for the payment of damages. All rights reserved in the event of the grant of a patent, utility model or design.

We reserve the right to change or modify our product specifications, configurations, or dimensions at any time without notice.



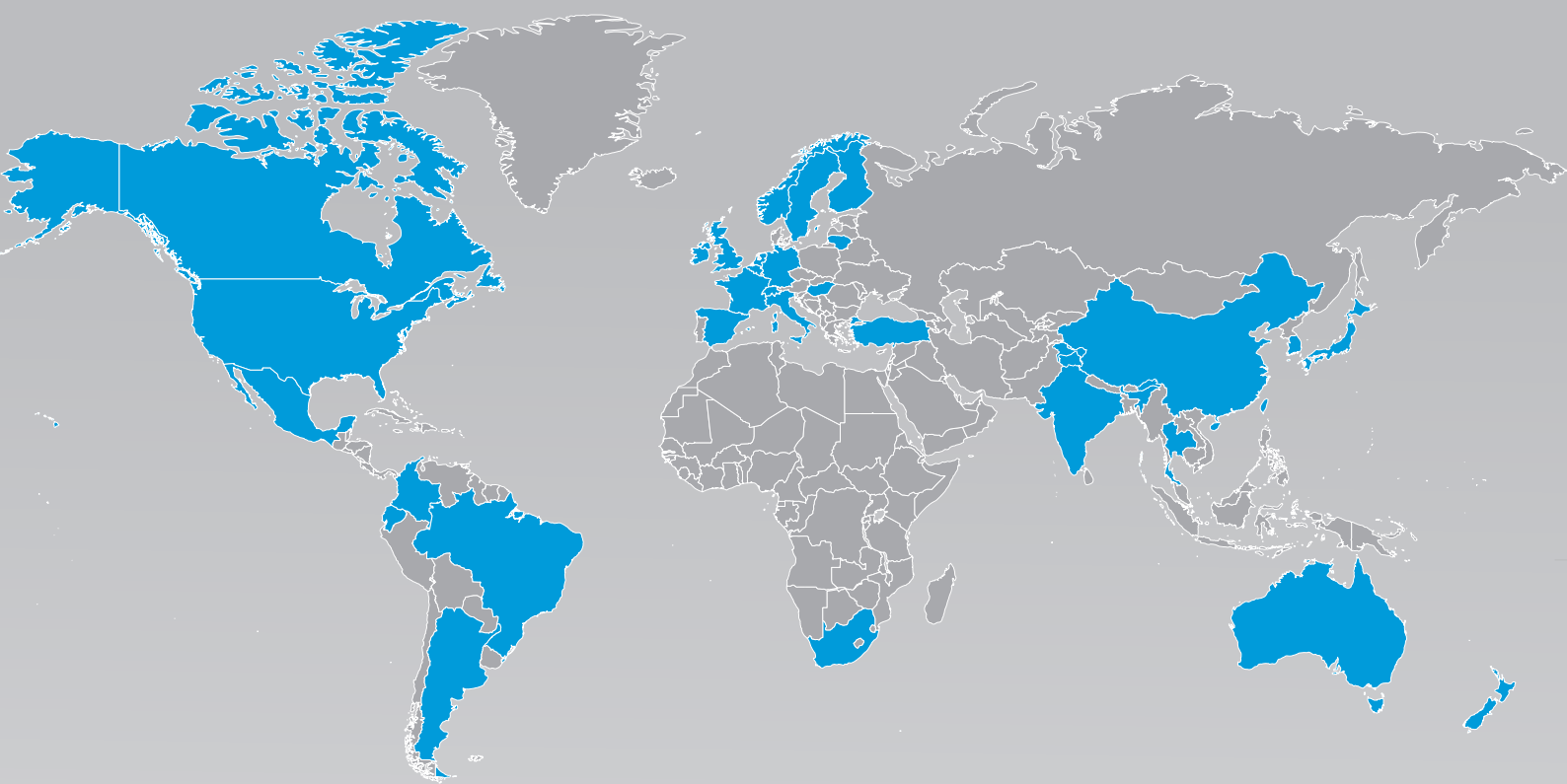

Technologies Customized to Every Part of the Globe

With a presence in 31 countries, Dana Incorporated boasts more than 150 engineering, manufacturing, and distribution facilities. Our worldwide network of local service centers provides assurance that each customer will benefit from the local proximity and responsiveness.

About Dana Incorporated

Dana is an integral partner for virtually every major vehicle and engine manufacturer worldwide. We are a leading supplier of drivetrain, sealing, and thermal technologies to the global automotive, commercial-vehicle, and off-highway markets. Founded in 1904, we employ thousands of people across six continents.



About Dana Off-Highway Drive and Motion Technologies

Dana delivers fully optimized Spicer® drivetrain and Brevini® motion systems to customers in construction, agriculture, material-handling, mining, and industrial markets. We bring our global expertise to the local level with technologies customized to individual requirements through a network of strategically located technology centers, manufacturing locations, and distribution facilities.

Learn more about Dana's drivetrain and motion systems at dana.com/offhighway.

Dana-Industrial.com

Application Policy

Capacity ratings, features, and specifications vary depending upon the model and type of service. Application approvals must be obtained from Dana; contact your representative for application approval. We reserve the right to change or modify our product specifications, configurations, or dimensions at any time without notice.



BREVINI®

Motion Systems